

# KOBOLD KAL-A (KAL-7000 Series) Thermal Flow Transmitter User Instructions





## Table of Contents

1.0	General	1
2.0	Specifications	1
2.1	Dimensions	3
3.0	Mechanical Installation	4
4.0	Electrical Connections	5
5.0	Operation	6
5.1	Calibration	6
5.1.1	Zero Flow Calibration	6
5.1.2	Adjustment of the Trend Indicator Span	7
5.2	Flow Setpoint adjustment	7
5.3	Setting the Transistor Switch Output Type	8
5.4	KAL-A Diagnostics	8
6.0	Maintenance	8
7.0	Arrival of Damaged Equipment	8
8.0	Need Help With Your KAL-A	9
9.0	Getting the Most out of Your KAL-A Transmitter	9
10.0	Application Hint: Relay Switching with the KAL-A Transistor Switch	11

## List of drawings

2.1	Dimensions	3
3.1	Mechanical Installation	4
5.1	Electrical Connections and Controls	5
5.2	Transmitter and Switch Wiring Configuration	5



**CAUTION: For safety reasons, please read the cautionary information located at the end of the manual, before attempting installation.**

## 1.0 General

The KOBOLD KAL-A (a.k.a. KAL-7000 Series) flow transmitter is intended for use in measuring and control applications involving moderate flowrates of non-viscous or dirty liquids. The KAL-A flow transmitter uses the proven thermal dispersion principle and operates as follows:

1. The probe is heated internally to a few degrees above the temperature of the medium into which it extends.
2. The flowing medium removes this heat from the probe by convective heat transfer. The rate at which heat is removed is proportional to the liquid velocity across the probe tip.
3. The electronics module converts the signal from the probe to a 4-20 mA signal which can be used to indicate flowrate.
4. For units provided with the optional flow switch, the measured flowrate is compared to the setpoint value selected by the user. If the setpoint is reached, the electronic circuitry activates a transistor switch and bi-colored alarm LED.
5. The electronic circuitry also controls an LED trend indicator which can be used to indicate relative system flow.

The microprocessor-controlled design permits simple calibration and setup. The compact probe design permits monitoring of flowrate with minimal head pressure loss.

## 2.0 Specifications

Measuring Range:	0.13-6.6 feet/sec. (0.04 - 2 meter/sec.)
Fitting Size:	1/2", 3/4" NPT
Optional:	1-1/2" Tri-Clamp®
Maximum Pressure:	
NPT:	1450 PSIG
Tri-Clamp®:	Per users' clamp rating up to 1450 PSIG
Normal Operating Temperature:	
Medium:	0 to 176°F
Ambient:	0 to 176°F
CIP (Clean In Place):	290°F max. up to 10 min. (unit is non-operational)
Wetted Parts:	
KAL-7215:	304 Stainless Steel
KAL-7315, 7320:	316-Ti Stainless Steel
KAL-7340S	316-Ti Stainless Steel

**Electrical Specifications:**

Supply Power:	24 VDC $\pm$ 10%, 300 mA Max.
Analog Output:	4-20 mA, 3 wire, 500 ohm Max. load impedance
Accuracy:	$\pm$ 10% of full scale
Repeatability:	$\pm$ 1% of full scale
Transistor Switch (optional):	
Switchpoint Adjustment:	By internal potentiometer
Switch Type:	Normally open (N/O) NPN or PNP transistor (user selectable) Max. 24 VDC, 400mA
Housing:	Reinforced PA6 (NEMA 4)
Calibration Data:	Stored in non-volatile memory, data retained for at least 10 years in the event of a power failure

**Table 2.1      Switching Ranges Vs. Pipe Diameter**

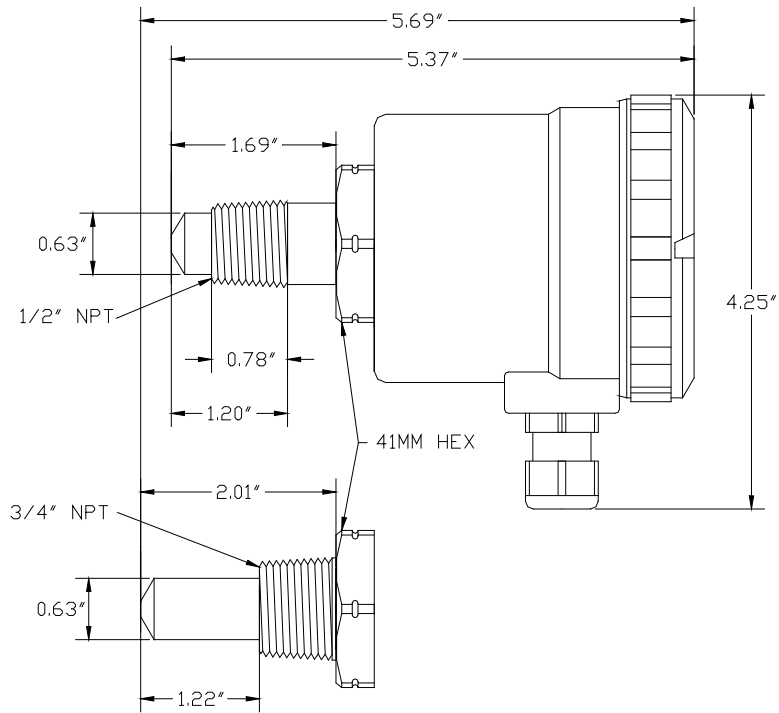
Nominal I.D Inches	Range GPM Water	Nominal I.D Inches	Range GPM Water
1/4	0.05-0.8	2-1/2	4.4-80
5/16	0.08-1.4	3-1/4	7.9-140
3/8	0.1-2.2	4	12-220
1/2	0.3-5.0	6	28-500
3/4	0.5-8.9	8	50-900
1	0.8-14	10	78-1400
1-1/4	1.1-20	12	110-2000
1-1/2	2.0-35	16	200-3600
2	3.1-55	20	310-5600

**Note:** The flow ranges specified in the table above have been calculated for each pipe diameter based on the known velocity range of the KAL-A. It must be noted that flow in pipes is non-uniform across the pipe cross section, and approaches zero at the pipe wall. This means that in practice, the depth of installation of the probe, the internal pipe diameter, and the effect that elbows valves and fittings can have on the flow profile of the liquid in the pipe can interact to produce significant deviations from the flow ranges in the above table.

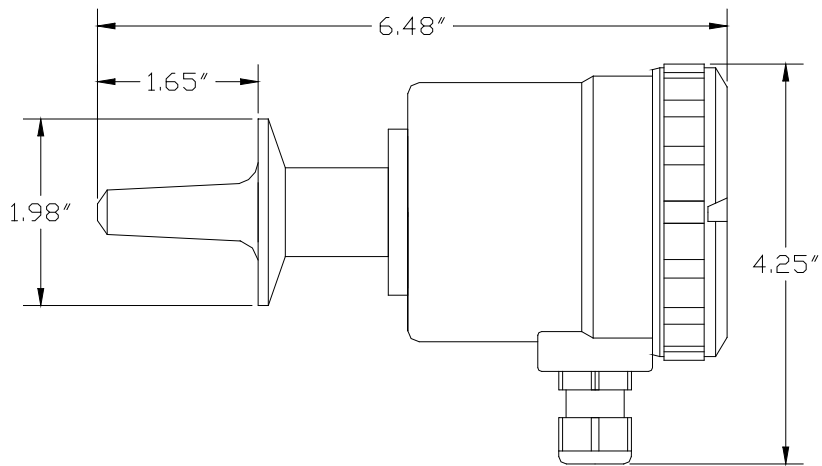
2.1

Dimensions

**KAL-7215, 7315, 7320**



**KAL-7340S**

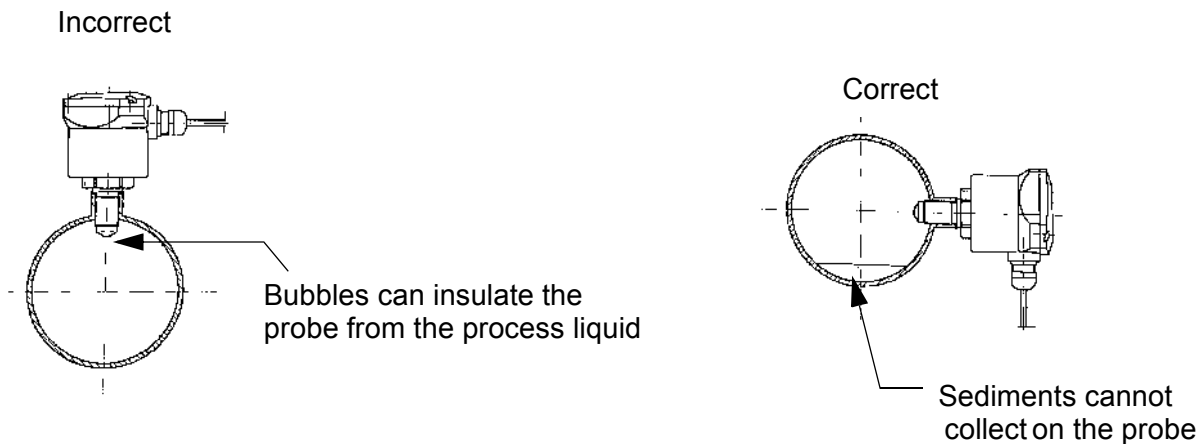


### 3.0 Mechanical Installation

To install the KAL-A flow transmitter into your piping system, proceed as follows:

- 3.0.1 The KAL-A flow transmitter can be mounted in virtually any orientation as long as the piping is completely filled with liquid. It is recommended that the unit be installed in the upper hemisphere of the pipe when being used in horizontal piping runs. This ensures that sediments do not deposit on the probe. It is also recommended that the probe not be installed in the very top of the pipe. In low pressure systems air bubbles which collect at the top of the pipe may keep the liquid from contacting the probe.

**Diagram 3.1** Mechanical Installation



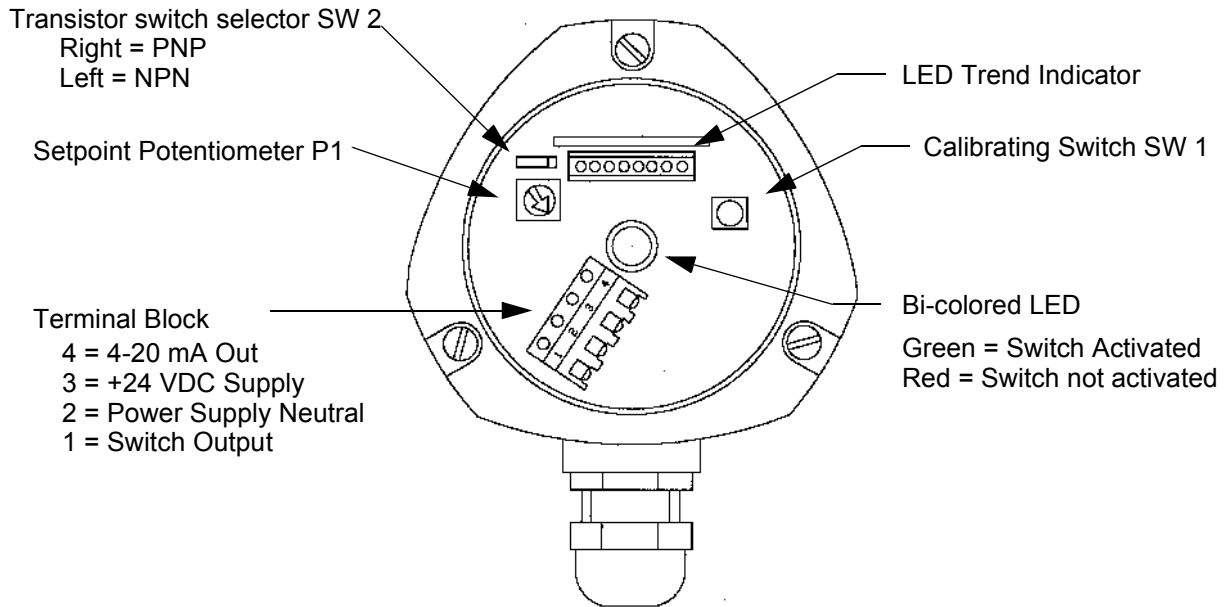
- 3.0.2 For optimal measuring accuracy, allow for a minimum of 5 pipe diameters of straight-run piping both upstream and downstream of the flow transmitter. This ensures that flow profile at the sensing probe is fully developed turbulent flow.
- 3.0.3 Prior to installation, ensure that the actual system flowrate is within the measuring range of the KAL-A. Additionally, ensure that the maximum system temperature and pressure are within the limits specified per Section 2.0, Specifications.
- 3.0.4 It is recommended that a thread sealant such as PTFE sealing tape be applied to the probe threads to ensure a leak-tight seal.
- 3.0.5 Using an appropriate sized wrench, carefully thread the sensor probe into the piping system. The probe must be installed such that at a minimum, the probe tip extends beyond the inner diameter of the piping and into the liquid stream. If this is not the case, the unit may still function but the measuring range will be somewhat higher than those stated in Table 2.1, Switching Ranges vs. Pipe Diameter.



4.0 Electrical Connections

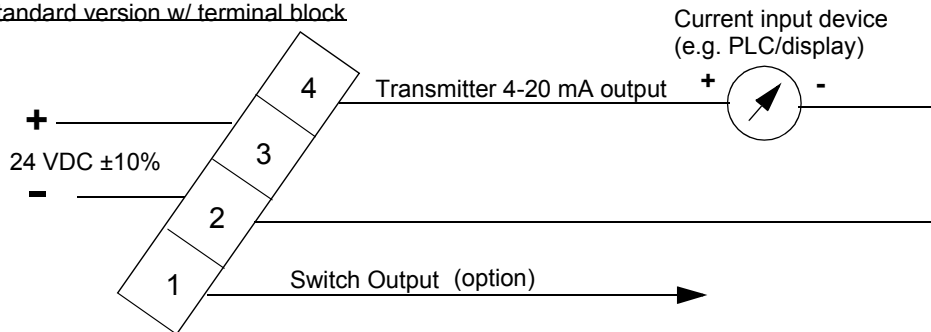
Diagram 4.1 shows the layout of electrical connections, as well as other controls for the KAL-A. Diagram 4.2 shows typical electrical wiring for the KAL-A transmitter and optional transistor switch configured as either a NPN (sinking) or PNP (sourcing) transistor switch. Instructions for selecting between the PNP or NPN output are provided in section 5.3, Switch Logic Selection. The KAL-A requires a 24 VDC, 300 mA power supply regulated to within  $\pm 10\%$ . If the same power supply will be used to provide current to devices being controlled by optional transistor switch (e.g. relays), sufficient additional current must be available to power these devices.

**Diagram 4.1** Electrical Connections and Controls

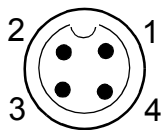


**Diagram 4.2** Transmitter and Switch Wiring Configuration

Standard version w/ terminal block



Optional M-12 connector version



- 1 = Brown (+24 VDC)
- 2 = White (+4-20 mA output)
- 3 = Blue (-DC Common)
- 4 = Black (Optional Switch Output)

Open collector transistor switch selectable between PNP and NPN

**PNP:** Switches 24 VDC to pin 1 when activated

**NPN:** Switches ground to pin 1 when activated

## 5.0 Operation

This section will provide details on the following aspects of KAL-A operation:

- Calibration of the zero-flow reference and trend indicator span.
- Adjustment of the flow switch setpoint.
- Switching between PNP and NPN transistor switch output.
- Self diagnostics within the KAL-A software.

### 5.1 Calibration

#### 5.1.1 Zero Flow Calibration

Calibration of the KAL-A electronics at zero system flow is necessary in order to obtain optimal performance from your KAL-A. This procedure allows the KAL-A to store data pertaining to the thermal characteristics of the liquid being monitored.

To perform the zero flow alignment, refer to Diagram 4.1 Electrical Connections and Controls, on page 5, and proceed as follows:

- 5.1.1.1 Ensure that the liquid system is in a no-flow condition.
- 5.1.1.2 Ensure that the system is completely filled and that the KAL-A sensing probe is completely immersed in liquid.
- 5.1.1.3 With power connected to the unit, turn setpoint adjustment potentiometer P1 counter-clockwise to its far left-hand stop.
- 5.1.1.4 Momentarily depress the calibrating switch SW1 and release. The bi-colored LED will flash green for a brief period while the unit is zeroing.

**Note:**

Do not adjust the setpoint potentiometer P1 while the bi-colored LED is flashing. Doing this will invalidate the zero calibration and the procedure will have to be repeated.

- 5.1.1.5 When the bi-colored LED stops flashing, the zero flow calibration is complete

### 5.1.2 Adjustment of the Trend Indicator Span

The KAL-A is factory preset to an arbitrary span value. The user must recalibrate the unit to a flow value consistent with his operating conditions. The maximum possible span corresponds to a flow velocity of 2 meters/second (6.6 feet/second). Full span flow will result in the illumination of all eight flow trend indicator LEDs and a transmitter current output of 20 mA. The KAL-A may be spanned to any flow value within its flow rate operating range. This allows the user to take advantage of the full range of the trend indicator and 4-20 mA transmitter.

To adjust the trend indicator span, refer to Diagram 4.1 Electrical Connections and Controls, on page 5, and proceed as follows:

5.1.2.1 With the system completely filled, adjust flow to its maximum value. This flow will correspond to the maximum transmitter output current of 20 mA when the span adjustment procedure is complete.

5.1.2.2 With power applied to the KAL-A, turn the setpoint potentiometer P1 clockwise to its far right-hand stop. Momentarily depress the calibrating switch SW1 and release. The bi-colored LED will flash green for a brief period while the unit self-adjusts the span.

**Note:**

Do not adjust the setpoint potentiometer P1 while the bi-colored LED is flashing. Doing this will invalidate the span adjustment and the procedure will have to be repeated.

5.1.2.3 When the bi-colored LED stops flashing, the span adjustment is complete. When the first measuring cycle after span adjustment is completed (approximately 10 seconds) all eight of the trend indicator LEDs should be lit and the transmitter should indicate 20 mA.

### 5.2 Flow Setpoint adjustment

The KAL-A thermal flow transmitter can be provided with an optional, adjustable, normally open (N/O) transistor switch. To adjust the flow switch setpoint, refer to Diagram 4.1 Electrical Connections and Controls, on page 5, and proceed as follows:

5.2.0.1 Adjust system flow to the value at which the setpoint is desired.

5.2.0.2 Potentiometer P1 adjusts the flow setpoint. The flashing LED on the trend indicator signifies the switch point. You will notice that the flashing LED moves along the trend indicator scale as potentiometer P1 is adjusted.

5.2.0.3 With system flow adjusted to the desired value, adjust potentiometer P1 until the KAL-A output switches state and the bi-colored LED changes color.

5.2.0.4 The KAL-A flow setpoint is now adjusted and system flow can be restored to normal.

### 5.3 Setting the Transistor Switch Output Type

The optional normally open transistor switch can be switched from NPN (current sinking) to PNP (current sourcing) by switching the DIP switch, SW 2, on the KAL-A circuit board (see Diagram 4.1). Switching the SW 2 to the left makes the switch NPN. Switching to the right makes it PNP.

The characteristics of the N/O switch, the bi-colored LED and the PNP or NPN transistor switch outputs are as follows:

#### **N/O Switch:**

System flow above the flow setpoint:

Switch = **ACTIVATED**

Bi-colored LED = **GREEN**

NPN Switch = **Pin 1 SWITCHED TO GROUND**

PNP Switch = **Pin 1 SWITCHED TO +24VDC**

System flow below the flow setpoint:

Switch = **DE-ACTIVATED**

Bi-colored LED = **RED**

NPN Switch = **Pin 1 HIGH RESISTANCE (open switch)**

PNP Switch = **Pin 1 HIGH RESISTANCE (open switch)**

### 5.4 KAL-A Diagnostics

The KAL-A has several diagnostic features. The KAL-A continuously self-monitors the sensing probe and micro-processor systems. Any fault in these portions of the electronics will be signaled by a flashing red bi-colored LED.

### 6.0 Maintenance

The KAL-A thermal flow transmitter is an electronically-controlled device with no moving parts. As a result the unit is virtually maintenance free. Occasional cleaning of the immersed probe may be required if the liquid media and/or process conditions are such that they tend to coat or build up an insulating film layer on the probe, affecting the functionality of the device. If this occurs, the unit should be removed from the system and any deposits or coatings on the probe removed using an appropriate method (such as a clean cloth) so as not to cause any damage to the probe surface. If, after cleaning, surface damage such as scratches, corrosion or pitting is noted, replace the device.

### 7.0 Arrival of Damaged Equipment

Your instrument was inspected prior to shipment and found to be defect-free. If damage is visible on the unit, we advise that you carefully inspect the packing in which it was delivered. If damage is visible, notify your local carrier at once. The carrier is liable for a replacement under these circumstances. If your claim is refused, please contact KOBOLD Instruments.

## 8.0 Need Help With Your KAL-A

Call one of our friendly engineers at 412-788-2830.

## 9.0 Getting the Most out of Your KAL-A Transmitter

- **Microprocessor Controlled**
- **Digital Temperature Compensation**
- **LED Flow Trend Indicator**
- **Analog Transmitter**
- **Optional Flow Switch Capability**
- **Compact Package**



This section provides information on using the automatic spanning features and superior repeatability of the KAL-A transmitter to optimize its flow transmitting capability in your system. With a proper understanding of how to set this unit up in a particular system and of the benefits and limitations of the thermal flow sensing technology we are quite certain that you will be pleased and satisfied with its performance.

### **Accuracy Versus Repeatability**

Accuracy is defined as the closeness of agreement between the result of a measurement (in this case transmitter output) and the true value of the process being measured. The accuracy of the KAL-A is  $\pm 10\%$ . What this means is that the current value transmitted from the KAL-A can be within  $\pm 10\%$  of the expected current value for a perfectly linear transmitter with 0% error.

Some of the factors that affect accuracy in a thermal type sensing probe are thermal lag between the liquid and the sensing element inside the probe, variations in probe insertion depth and the sensitivity and tolerances of the temperature sensing element and electronics. Although many of these errors can be overcome, the expense to do so would make our economical transmitter cost prohibitive.

Numerous applications require repeatability more so than they require high accuracy. Repeatability is defined as the closeness in agreement among a number of consecutive measurements taken under the same operating conditions. **KAL-A transmitter has a repeatability of  $\pm 1\%$ .** This means that the current output of the transmitter will repeat to within  $\pm 1\%$  for any given flow rate when that flow rate is reproduced at a later time. For applications where repeatability is most important, the KAL-A transmitter can be used with great success.

## The Added Benefit of Microprocessor Controlled Temperature Compensation

Thermal type flow devices measure flow by heating a probe tip immersed in liquid. As the liquid flows across the tip, the tip is cooled. The rate at which the tip is cooled is proportional to flow-rate. The cooling rate is sensed by the electronics and converted to a flow signal. Liquid temperature also affects the probe cool-down rate. Without temperature compensation within the flow measuring device, changes in liquid temperature would be misunderstood by the measuring electronics as a change in flowrate resulting in a false flow measurement. Temperature compensation is achieved by taking liquid temperature measurements at the beginning and end of each measuring cycle (approximately every six seconds). Any change in liquid temperature is sensed and a correction is applied to the transmitted flow signal.

What makes our thermal flow transmitter unique and superior to all others is that we employ a microprocessor to compensate for temperature changes rather than a single solid state electronic circuit. The main benefit of using microprocessor controlled temperature compensation is that digital compensation is not subject to errors and setpoint drift which are caused by varying tolerances of the individual components in a solid state compensation circuit. Additional benefits are increased response time and the ability to store a large volume of liquid compensation data.

The following are some examples of applications where the KAL-A transmitter's high degree of repeatability is important and high accuracy is not necessarily required:

### Example 1:

A particular user has a mechanical flowmeter in a system where it is desired to transmit a 4-20 mA signal to a remote device. The KAL-A can be installed in this system and the mechanical flowmeter can be used as a reference to determine what the current output will be for corresponding flow rates. Although not necessarily linear this current output characteristic will be repeatable to within  $\pm 1\%$ .

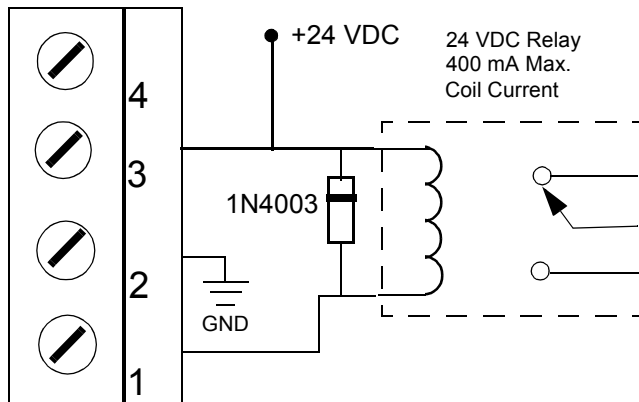
### Example 2:

The KAL-A is to be used with a PLC or data acquisition device which is capable of linearizing a non-linear signal. If there is an ability to take a direct measurement of flow rate at various points over the desired measuring range, the current output of the KAL-A can be measured and linearization performed. This method again takes full advantage of the high degree of repeatability of the KAL-A transmitter.

### Example 3:

It is desired to transmit system flow rate to a 4-20 mA control room indicator that indicates 0 to 100% flow. For this particular application 100% flow is the normal, steady-state operating system flow rate. Flows of less than or greater than normal steady-state operating system flow would only be encountered during start-up, shutdown or abnormal conditions such as equipment failure. In this application the KAL-A can be easily spanned to indicate 20 mA (or 100% flow) at the normal system flow rate. This is done by installing the KAL-A in the system, adjusting the span potentiometer to the far right-hand stop and depressing the span/calibrate push-button while the system is flowing at steady state. Additionally, the optional flow alarm switch can be used to alarm a high flow condition. and the 4-20 mA signal transmitted to the control room display can be used to monitor system flows below 100% during start-up and shut down.

## 10.0 Application Hint: Relay Switching with the KAL -A Transistor Switch



### How is it done?

The diagram shows the wiring interconnections required to connect a relay coil to our transistor switch. Any 24 volt DC relay will work as long as the coil current is less than the 400 mA current rating of the KAL-A transistor switch. The diode is installed across the relay coil and acts as a voltage spike suppressor protecting the KAL-A transistor. Any 1N4000 series diode will work, and any electronics supply house will have these diodes. Also, **it is important that the KAL-A is switched to the NPN output mode.** This is done by switching the red DIP switch on the upper left hand portion of the circuit board to the left. (see diagram 4.1, page 5.)





**CAUTION**

PLEASE READ THE FOLLOWING WARNINGS BEFORE ATTEMPTING  
INSTALLATION OF YOUR NEW DEVICE. FAILURE TO HEED THE  
INFORMATION HEREIN MAY RESULT IN EQUIPMENT FAILURE AND  
POSSIBLE SUBSEQUENT PERSONAL INJURY.



- **User's Responsibility for Safety:** KOBOLD manufactures a wide range of process sensors and technologies. While each of these technologies are designed to operate in a wide variety of applications, it is the user's responsibility to select a technology that is appropriate for the application, to install it per these installation instructions, to perform tests of the installed system, and to maintain all components. The failure to do so could result in property damage or serious injury.
- **Proper Installation and Handling:** Use a proper sealant with all installations. Never overtighten the unit within the fitting. **Never use the housing to thread the unit into its fitting.** Always use only an appropriate sized wrench on the hex portion of the probe. Always check for leaks prior to system startup.
- **Wiring and Electrical:** In all versions, a supply voltage of 24 VDC  $\pm 10\%$  is used to power the KAL-A. The sensor systems should never exceed this rating. Electrical wiring of the sensor should be performed in accordance with all applicable national, state, and local codes.
- **Temperature and Pressure:** The KAL-A is designed for use in normal operating temperatures from 0 to 176°F, and for use at pressures up to 1450 PSIG for threaded probes. Tri-Clamp® probes are rated to the pressure rating of the user supplied clamp. Normal operation outside these limitations will cause damage to the unit and possible personnel injury.
- **Material Compatibility:** The KAL-A sensor probe is made of either 304 or 316-Ti stainless steel. The housing is constructed of PA6. Check your model number with the wetted materials specification in Section 2.0, "Specifications", on page 1 of this manual. Make sure that the model which you have selected is chemically compatible with the application liquids. While the switch housing is splash resistant when installed properly, it is not designed to be immersed. It should be mounted in such a way that it does not normally come into contact with fluid.
- **Flammable, Explosive and Hazardous Applications:** KAL models should not be used in areas where an explosion-proof design is required.
- **Make a Fail-Safe System:** Design a fail-safe system that accommodates the possibility of switch or power failure as well as operator error. In critical applications, KOBOLD recommends the use of redundant backup systems and alarms in addition to the primary system.