

SHPFI

Smart Frequency to Current Converter & Pulse Scaler

Installation and Operating Instructions



KESSLER-ELLIS PRODUCTS

10 Industrial Way East

Eatontown, NJ 07724

800-631-2165 • 732-935-1320

Fax: 732-935-9344



<http://www.kep.com>



Contents

Description.....	1
Specifications	1
Dimensions:.....	2
SHPFI-M-0.....	2
SHPFI-M-2.....	2
SHPFI-M-3.....	2
Theory Of Operation.....	3
Flow rate equation	3
20 Point Linearization Option	3
Wiring	3
Typical Wiring	3
Flow total equation:	3
Getting Started	4
Installing the setup program for the SHPFI	4
Step 1 - Electrical Connections	4
Step 2 - PC Setup Software	4
Step 3 - Basic Setup.....	5
Step 3a - Rate Setup	6
Step 3b - Totalizer Setup	7
Step 4 - Setup of the Flow Sensors K-Factor	8
Step 4a - Average K-Factor Setup.....	8
Step 4b - Linearization Table Setup.....	9
Step-5 - Pulse Output Setup.....	10
Step-6 Analog Output Setup.....	11
Step 7 - Printing Setup Information	12
Step-8 - Download Configuration to SHPFI.....	13
Step 9 - Save Configuration File.....	14
Step 10 - Viewing Computed Rate and Total.....	15
Operation.....	16
Analog Output Calibration	17
Decoding Part Number:.....	18
Warranty	18

SPECIFICATIONS

Description

The SHPFI-M is a smart frequency to current converter and also a frequency to frequency pulse scaler. It is intended to be used with flow meters and similar devices who generate a pulse signal either from a magnetic pickup or a contact closure whose frequency is related to flow rate and where each pulse represents a quantity of flow. The SHPFI-M also contains a linearization function commonly required by flow meters to improve their accuracy. The flow rate and total are computed within the SHPFI-M and the 4-20mA analog output and the high level scaled pulse output are generated from these computed values. The SHPFI-M is programmed using a special setup program from a PC. A special programming cable called the BSAC1 is also required. These items are purchased separately. The computed Rate and Total may also be viewed on your PC using these special cables.

Specifications

POWER:

LOOP POWERED

Voltage: 8.5 to 30 VDC
Protection: Reverse Polarity Protection on Current Loop
Loop Burden: 8.5V maximum

COMPUTATION:

Rate Computation

5 Digits (99999), updates 8X per second
Time base: /SEC, /MIN, /HR/DAY
Min. Input Frequency: 0.01 Hz to 10 Hz (selectable delay of 0.1 to 99.9 seconds) Selectable Rate Damping

PULSE OUTPUT OF COMPUTED TOTAL:

The pulse output advances with the least significant digit of the computed totalizer or decimal multiples thereof (see Pulse scale divider).
Type: Isolated photomos relay
Max. voltage (off state): 30 VDC
Current (on state): 100mA
Pulse Duration: Selectable 0.5, 0.25, 0.125, 0.0625 seconds
Pulse Scale divider (Pulscale): User selectable, +1, +10, +100 or OFF

ACCURACY:

0.01% Computed Rate, ±1 least significant digit of computed rate
Temperature Drift: 50 ppm/°C Worst Case

ENVIRONMENTAL:

OPERATING TEMPERATURE

-4°F (-20°C) to +158°F (70°C)
Extended Temp: -22°F (-30°C) to +158°F (70°C)

HUMIDITY

0 - 90% Noncondensing

MOUNTING STYLES:

- 0- OEM- OEM option
- 2- Wall Mount - NEMA 4X Enclosure
- 3- Explosion Proof - Class I, Division I, Groups B, C & D
Class II, Division I, Groups E, F & G

NOTE: Meter mounting kits available (consult Factory)

INPUTS:

MAGNETIC PICKUP INPUT

Frequency Range: 0 to 3500 Hz
Trigger Sensitivity: 10 mV p-p (nominal)
Over Voltage Protected: ± 30 VDC

OPTO-ISOLATED DC PULSE INPUT

High (logic 1): 4-30 VDC
Low (logic 0): Less Than 1 VDC
Minimum Current: .5 mA
Hysteresis: 0.4 VDC
Frequency Range: 0 to 5 kHz
Min. Pulse Width: 0.1 msec

CONTACT CLOSURE INPUT (contact closure to common)

Internal Pullup Resistor: 100 KΩ to +3.6 VDC
High (logic 1): Open or 4-30 VDC
Low (logic 0): Less Than .5 VDC
Internal Switch Debounce Filter: 0 to 40 Hz (others on request)

K-FACTOR

Range: 0.001 to 99999999
Decimal Point Locations: XXXX.XXXX to XXXXXXXX

20 POINT LINEARIZATION

This feature allows the user to enter 20 different frequencies with 20 different corresponding K-Factors to linearize non linear signals.

ANALOG OUTPUT:

Type: 4-20 mA follows computed rate display, Two wire hookup
Accuracy: 0.025% Full Scale at 20° C
Temperature Drift:
50 ppm/°C Typical
Reverse Polarity Protected
Update Rate: 8 times/second

COMMUNICATIONS ACCESSORY:

RS232 SERIAL SETUP SOFTWARE

This accessory enables you to access a variety of process parameters through serial communications. PC compatible communications software is included with this cable. With this software and a Serial Adapter Cable (BSAC1) you will be able to setup the unit through your PC.

Dimensions:

SHPFI-M-0

OEM Mount (Mounting option 0):

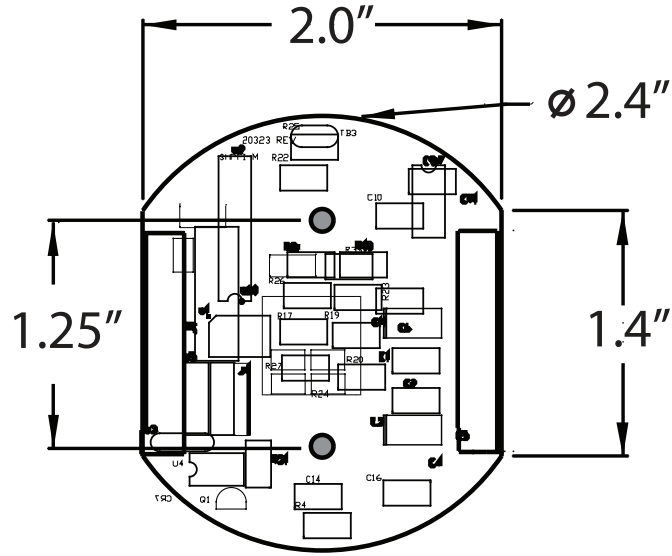

SHPFI-M-2

NEMA4 Wall Mount (Mounting option 2):

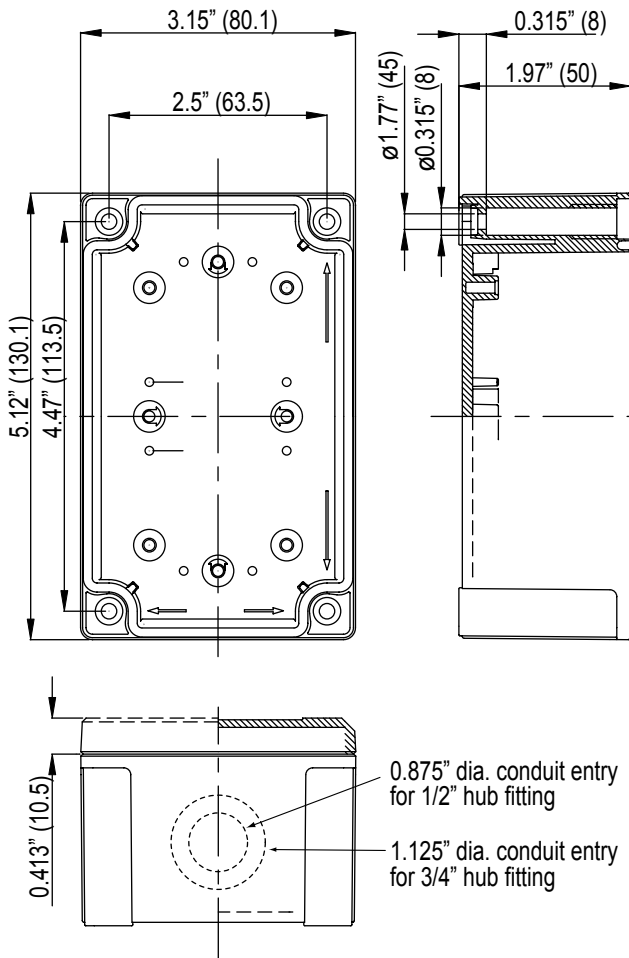

SHPFI-M-3

Explosion Proof Enclosure (Mounting option 3):

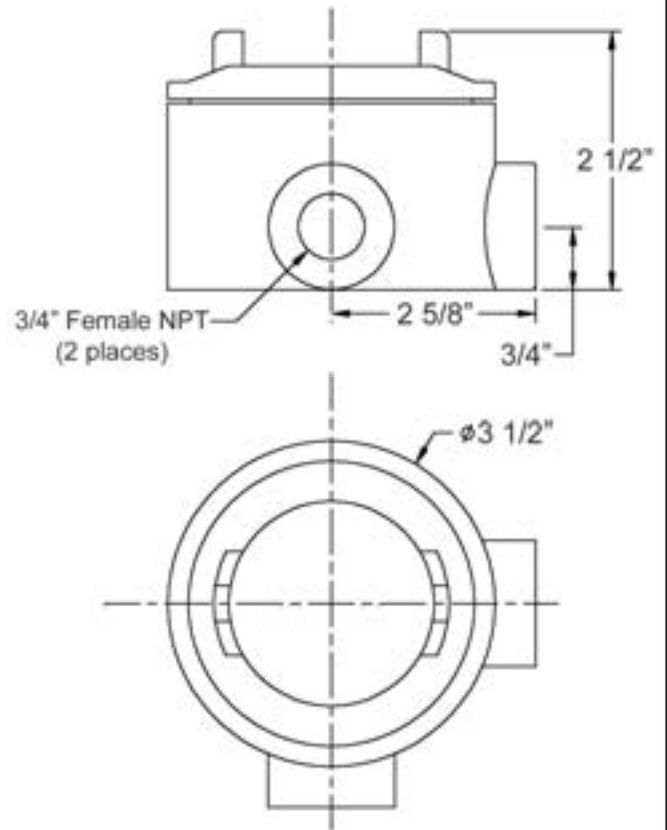

THEORY OF OPERATION

Flow rate equation:

$$\text{Flow Rate Indication} = \frac{\text{Input Frequency}}{\text{FAC}} \times \text{Time Scaler}$$

Where Time Scaler is equal to: 1 for rate per second read out
 60 for rate per minute read out
 3600 for rate per hour read out
 86400 for rate per day read out

Flow total equation:

$$\text{Flow Total} = \frac{\text{Sum of Input Pulses}}{\text{FAC}}$$

20 Point Linearization Option:

A 20 point linearization table is used to construct a curve describing the relationship of K-Factor and input frequency. The measured input frequency is used to access the table. A linear interpolation of adjacent point pairs is used to arrive at the K-Factor at that input frequency. The flow rate and total are then computed based upon the K-Factor for that measurement sample.

NOTE: For best performance and resolution choose as many decimal places as possible in the K-Factor.
 Example: Enter a K-Factor of 1 as 1.000.

WIRING

Several typical applications of the SHPFI are shown below. Please observe that the various pulse inputs and power options may be intermixed in many ways to solve common applications. The isolated pulse output may be freely used so long as proper polarity is observed.

Caution: When 4-20 mA loop option is provided, the power wiring to the loop power option should always be to terminals (+) 12 and (-) 11.

Caution: The magnetic pickup input and contact closure input require isolated sensors for proper operation. Accidental connections to earth may result in erroneous operation of the analog output and/or excessive current flow.

Caution: Accidental connections from circuit common (3 or 6) to earth or terminal (11) may result in erroneous operation of the analog output and/or excessive current flow.

Typical Wiring

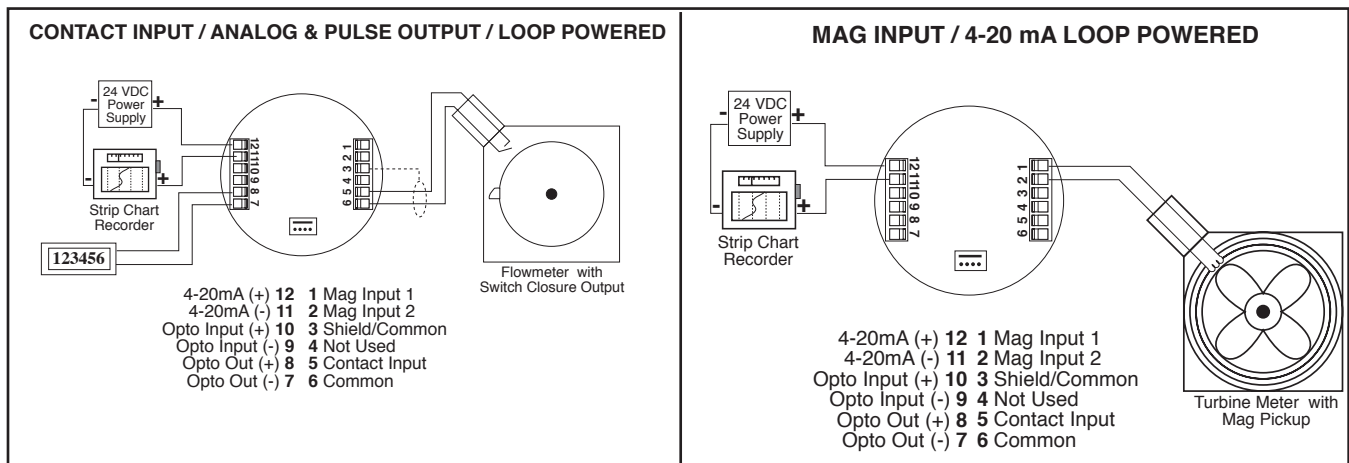

Getting Started

Installing the setup program for the SHPFI

The following is an over view of the process used to program the SHPFI-M.

Step 1 - Electrical Connections

Connecting the Power Supply and BSAC1 to the SHPFI as shown in the figure. Apply 24 Vdc terminal 12(+) and terminal 11 (-). Connect the BSAC1 to the RS232 Port on your PC. Turn 24 Vdc Power On.

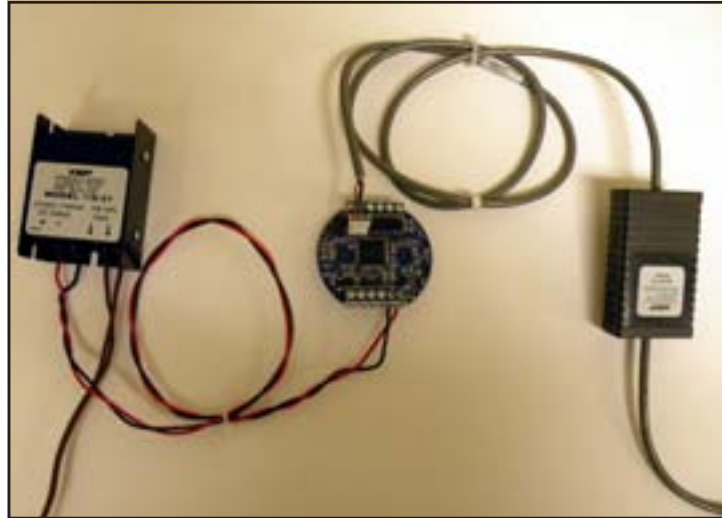

Step 2 - PC Setup Software

Launch the PC Setup Program and Select the SHPFI's template

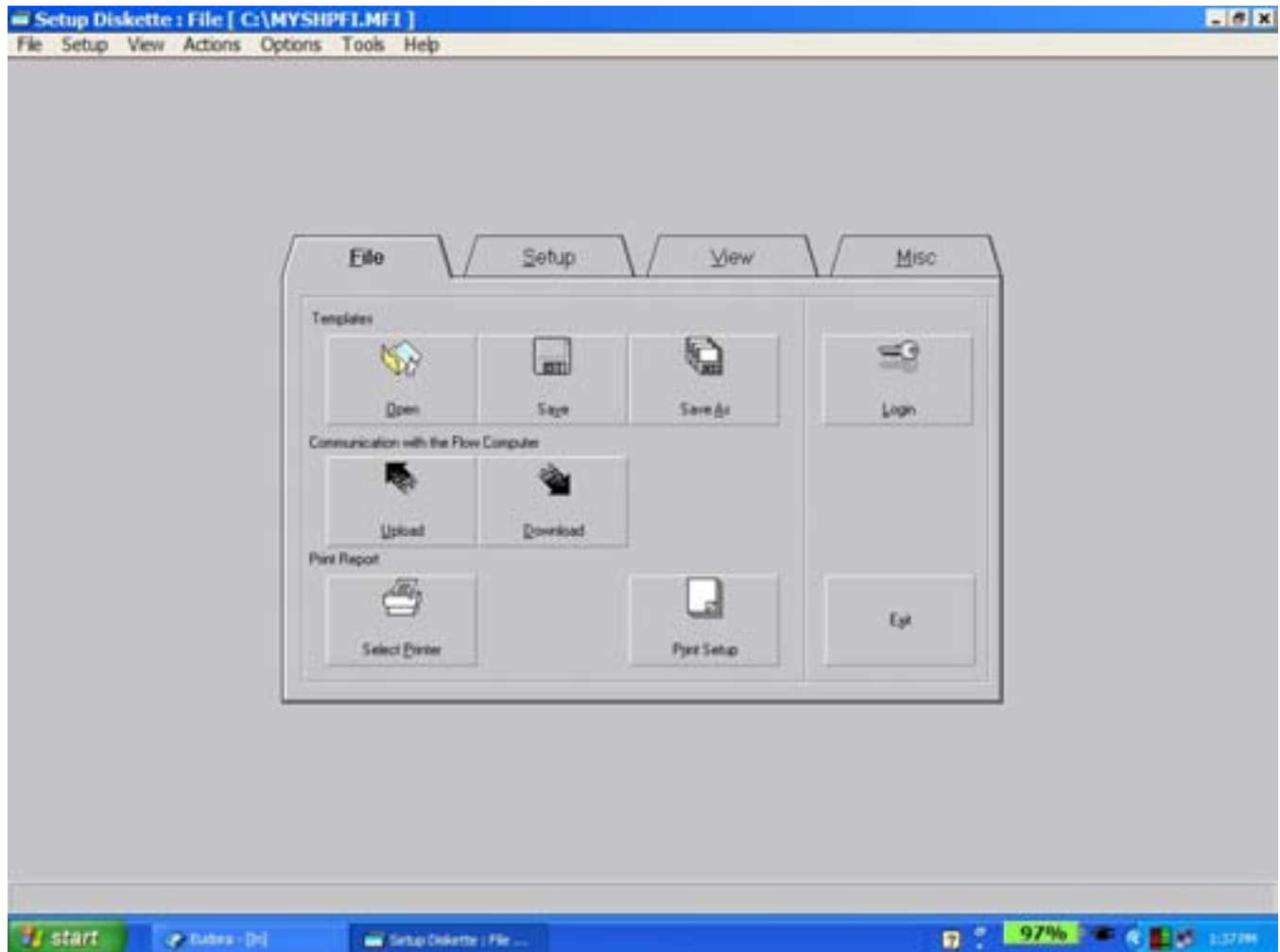

Step 3 - Basic Setup

Select the Setup Folder and click on the item labeled Setup Indicators.

Choose the SHPFI. Next choose the time base and units of measure to be used in the SHPFI.

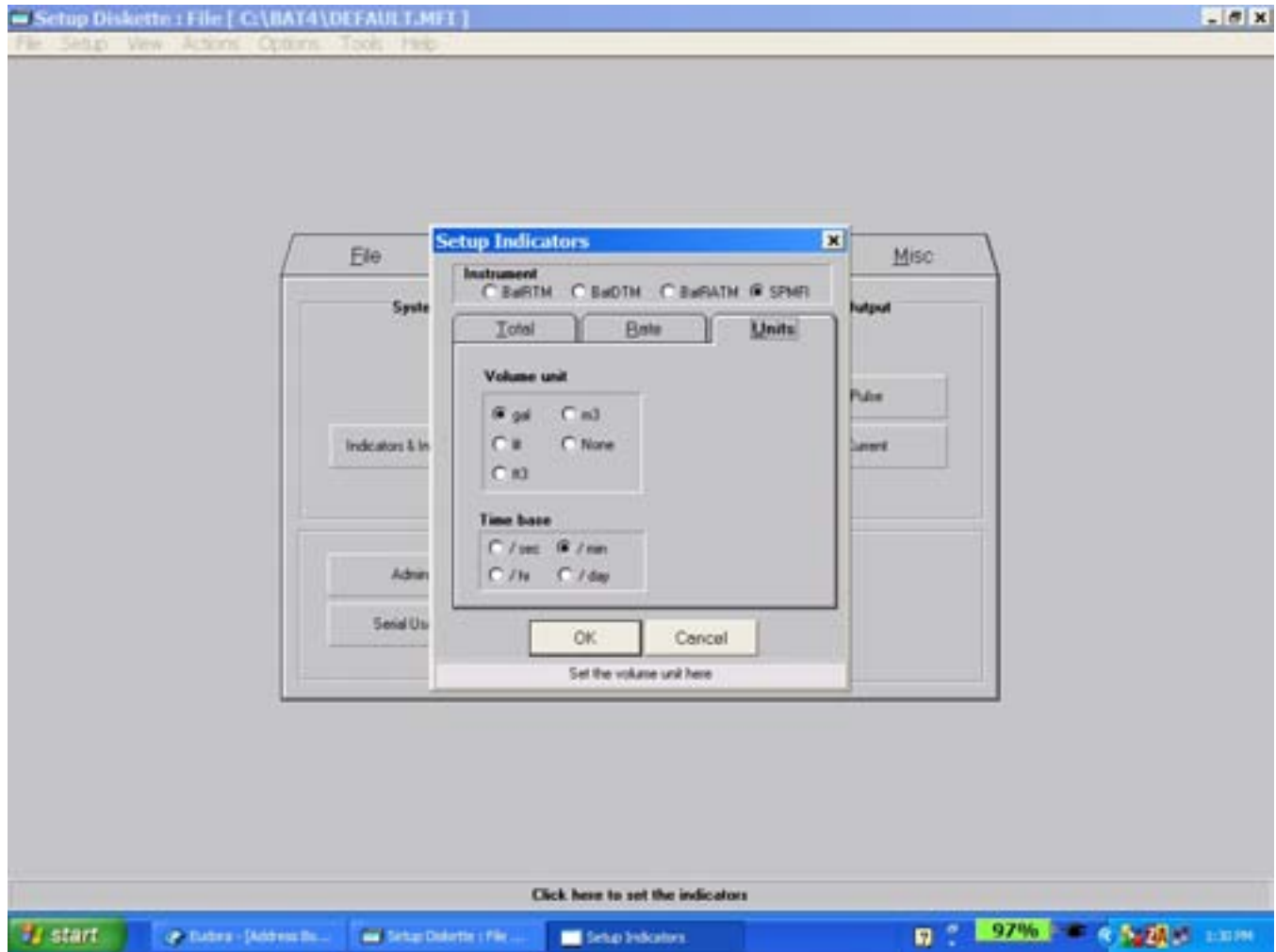

Step 3a - Rate Setup

Setup of the internal rate calculation is done on the Rate tab of the Setup Indicators. The internal rate is computed to up to 5 significant figures with a user selectable decimal; point position. Choose the decimal point position that will result in the flowrate being computed to the maximum precision while not exceeding 5 digits. The delay is the maximum time in seconds between pulses that you wish to wait before the SHPFI decides the flow rate should be treated as 0. The Rate Averaging is a number related to the amount of filtering of computed rate. A value of 0 means no filtering. A value of 9 means maximum filtering.

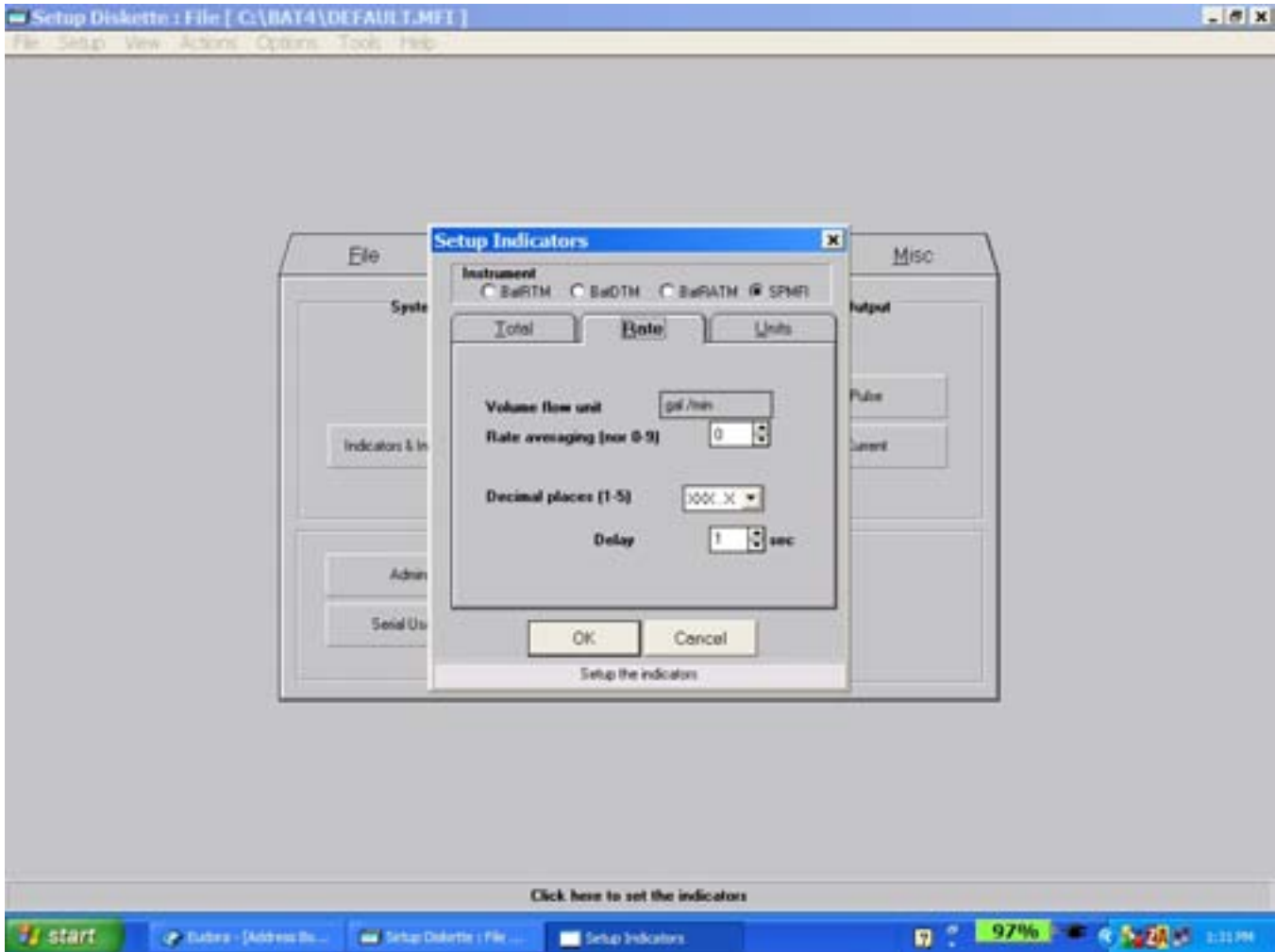

Step 3b - Totalizer Setup

The internal totalizer is computed to 8 digits. The pulse output is driven by the least significant digits of the total. Setup the internal totalizer decimal point to correspond to the resolution expected of the pulse output.

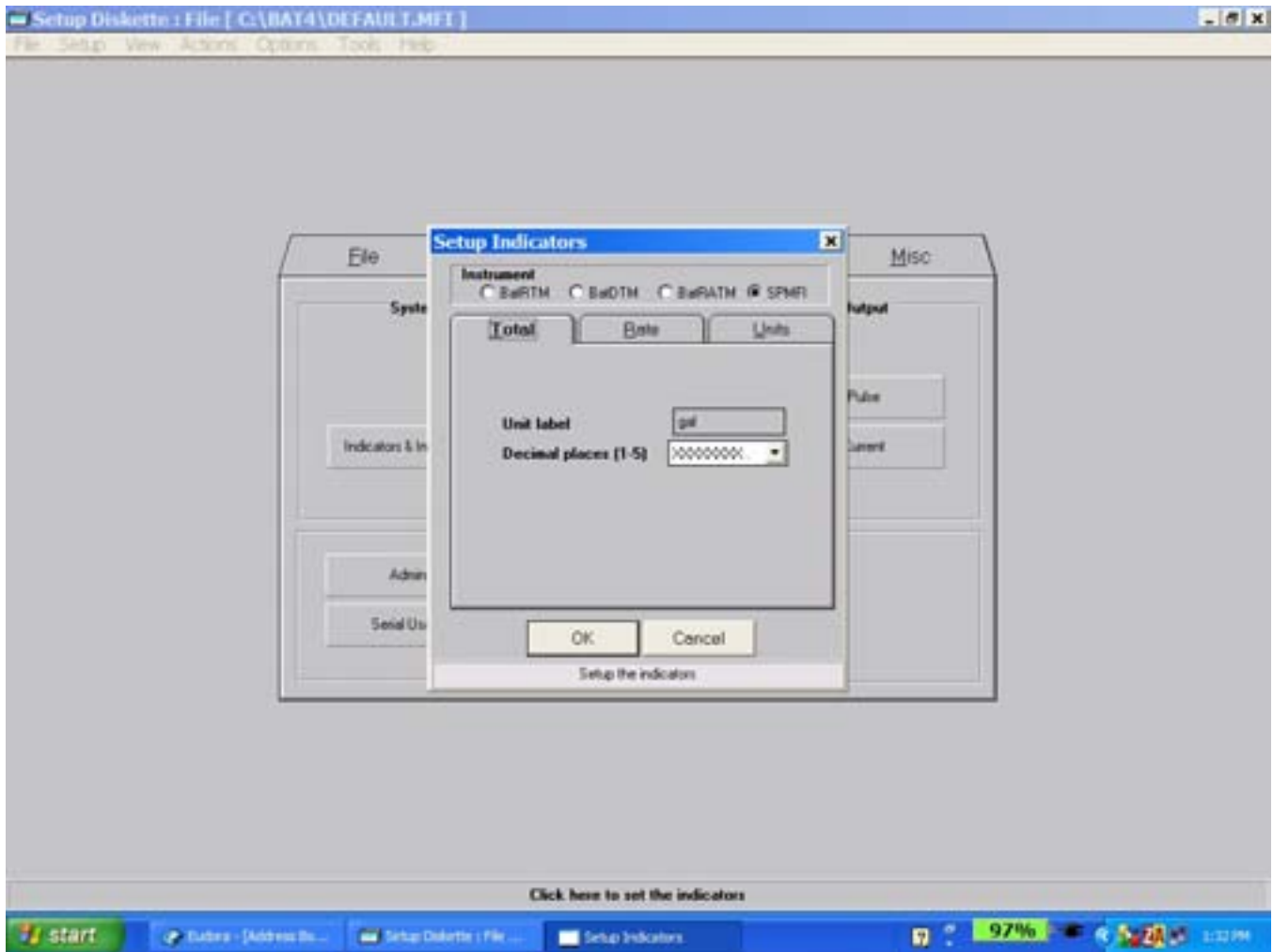

Step 4 - Setup of the Flow Sensors K-Factor

The SHPFI supports the use of either a constant K-Factor for the flow sensor or a linearization table. Begin by choosing the meter type you wish to use in the SHPFI.

Step 4a - Average K-Factor Setup

If you have decided that your sensor can be treated as just an average K-Factor then choose the decimal point and the K-Factor for the sensor. Click OK when done.

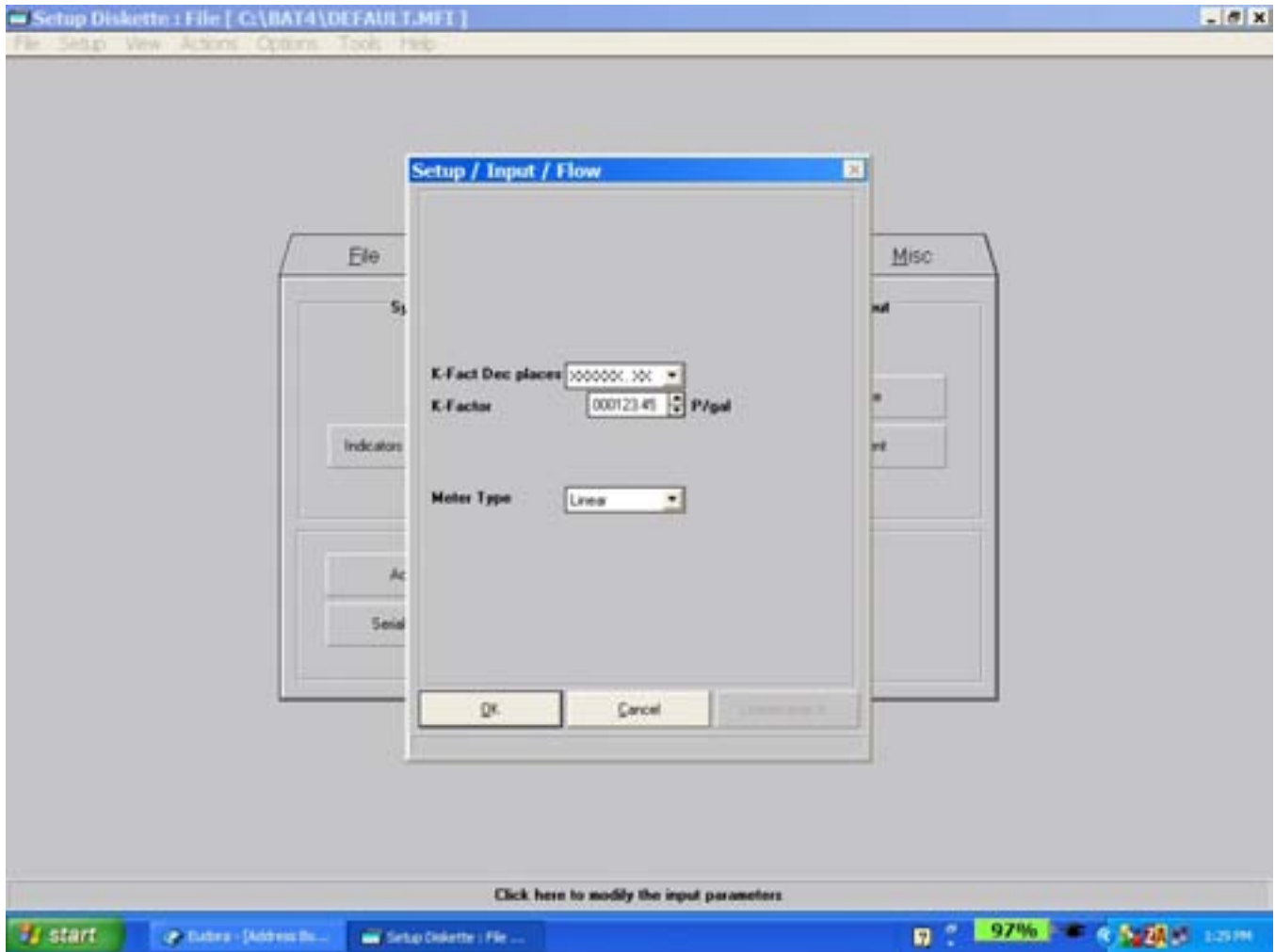

Step 4b - Linearization Table Setup

If you have decided that your sensor should be treated as a linearization table then enter the frequency/K-Factor point pairs in ascending order of frequency. Click OK when done.

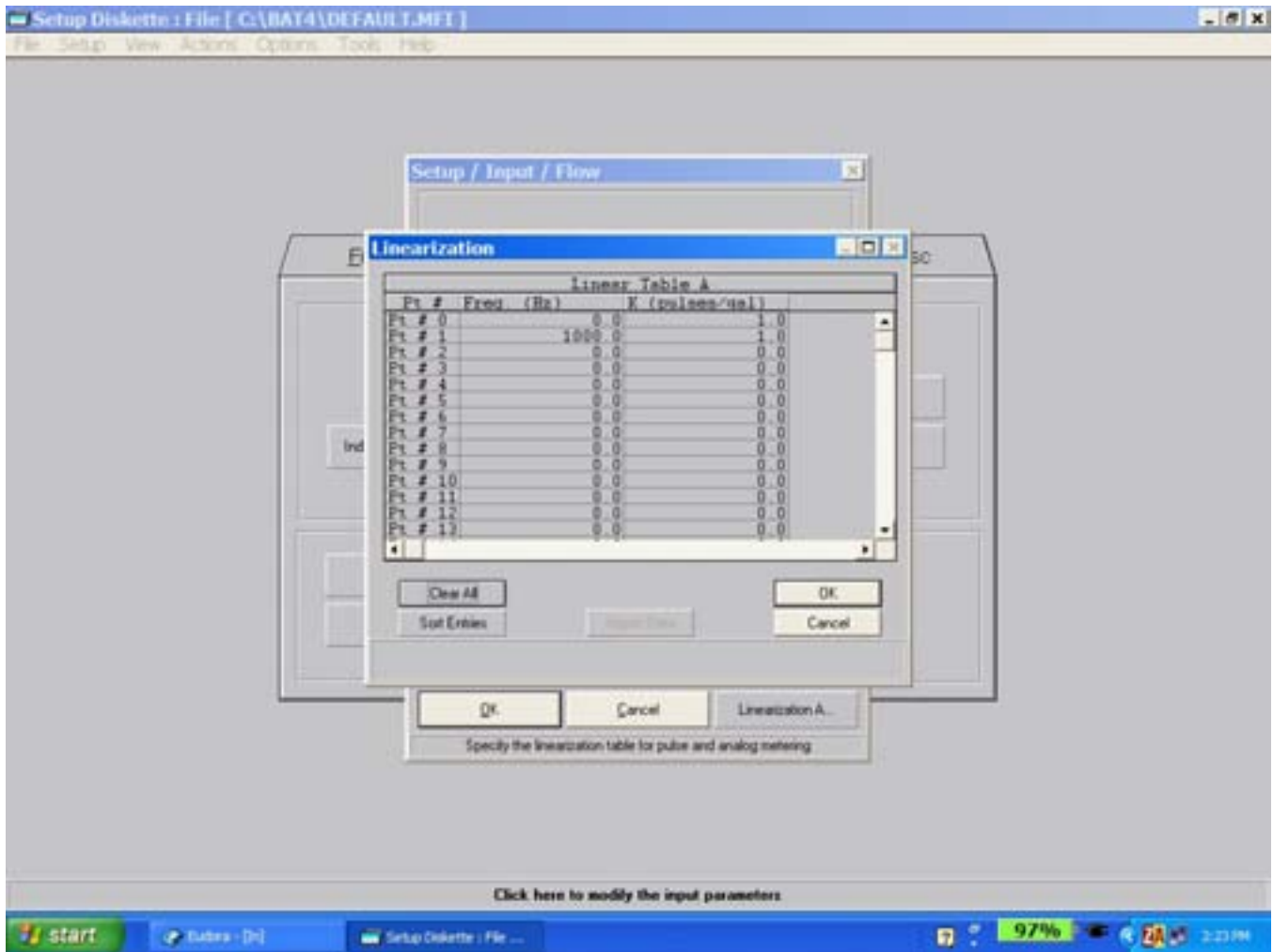

Step-5 - Pulse Output Setup

Setup of the scaled pulse output is entered on the Setup/Output/Pulse pop up. Choose the Pulse Divider and Pulse Width required by the application.

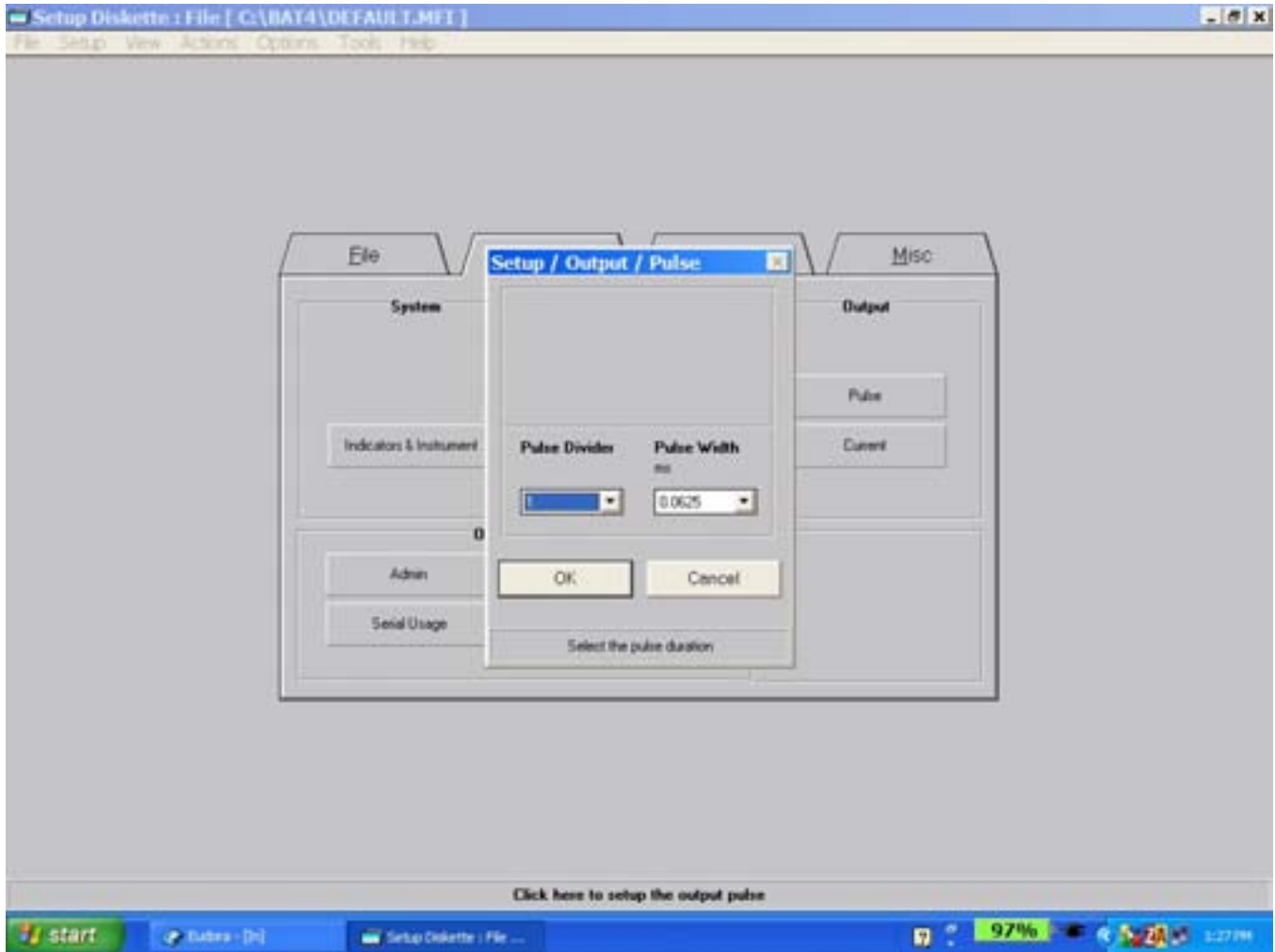

Step-6 Analog Output Setup

Setup of the Current Output is entered on the Setup/Output/Current pop up. Enter the low scale and full scale you desire. Click OK when done.

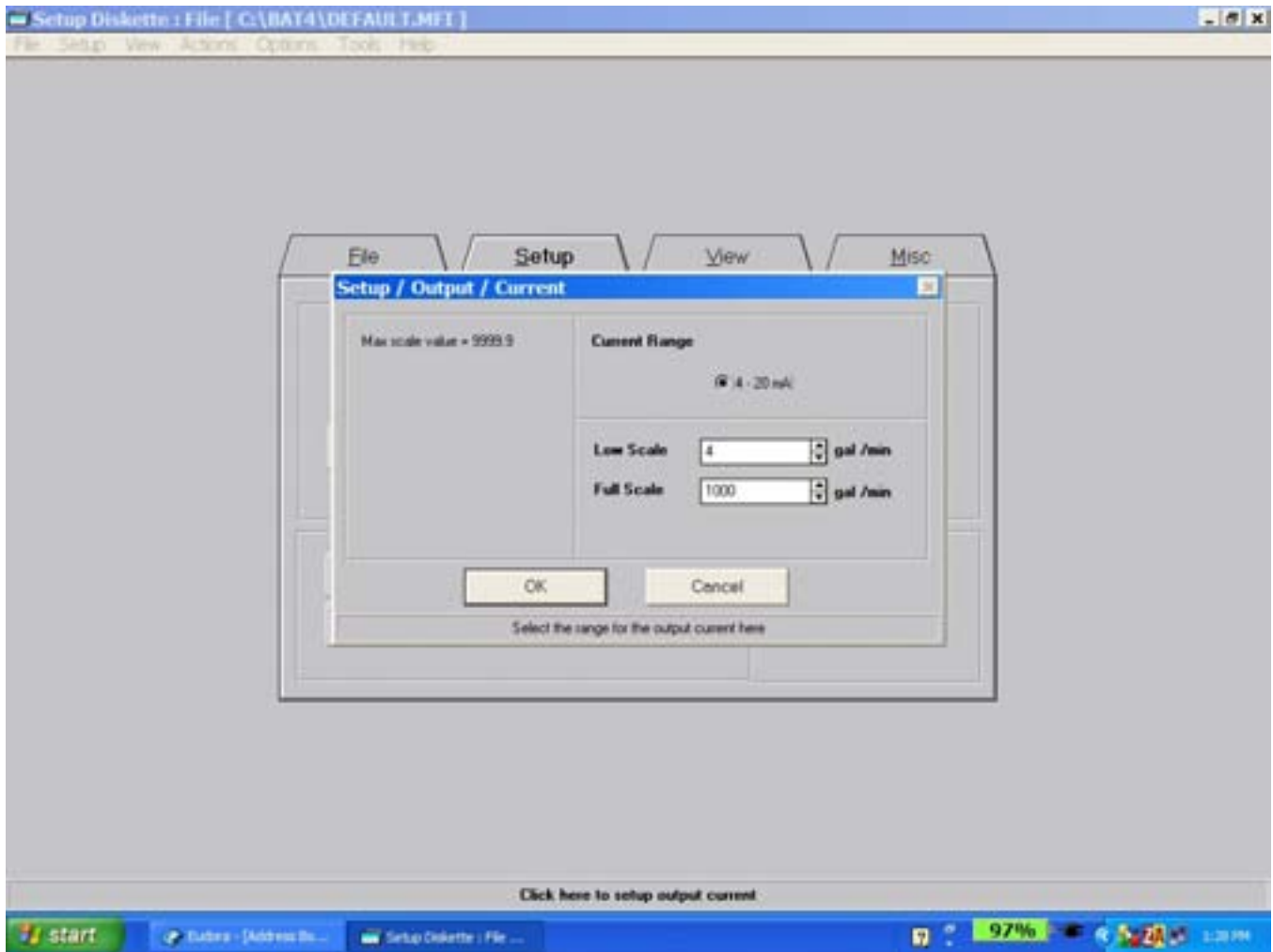

Step 7 - Printing Setup Information

A copy of the setup can be printed for your records on the File Tab by clicking the PRINT setup control. A sample will pop up, then press PRINT to generate the print out via your PC's default printer. Click Close when done.

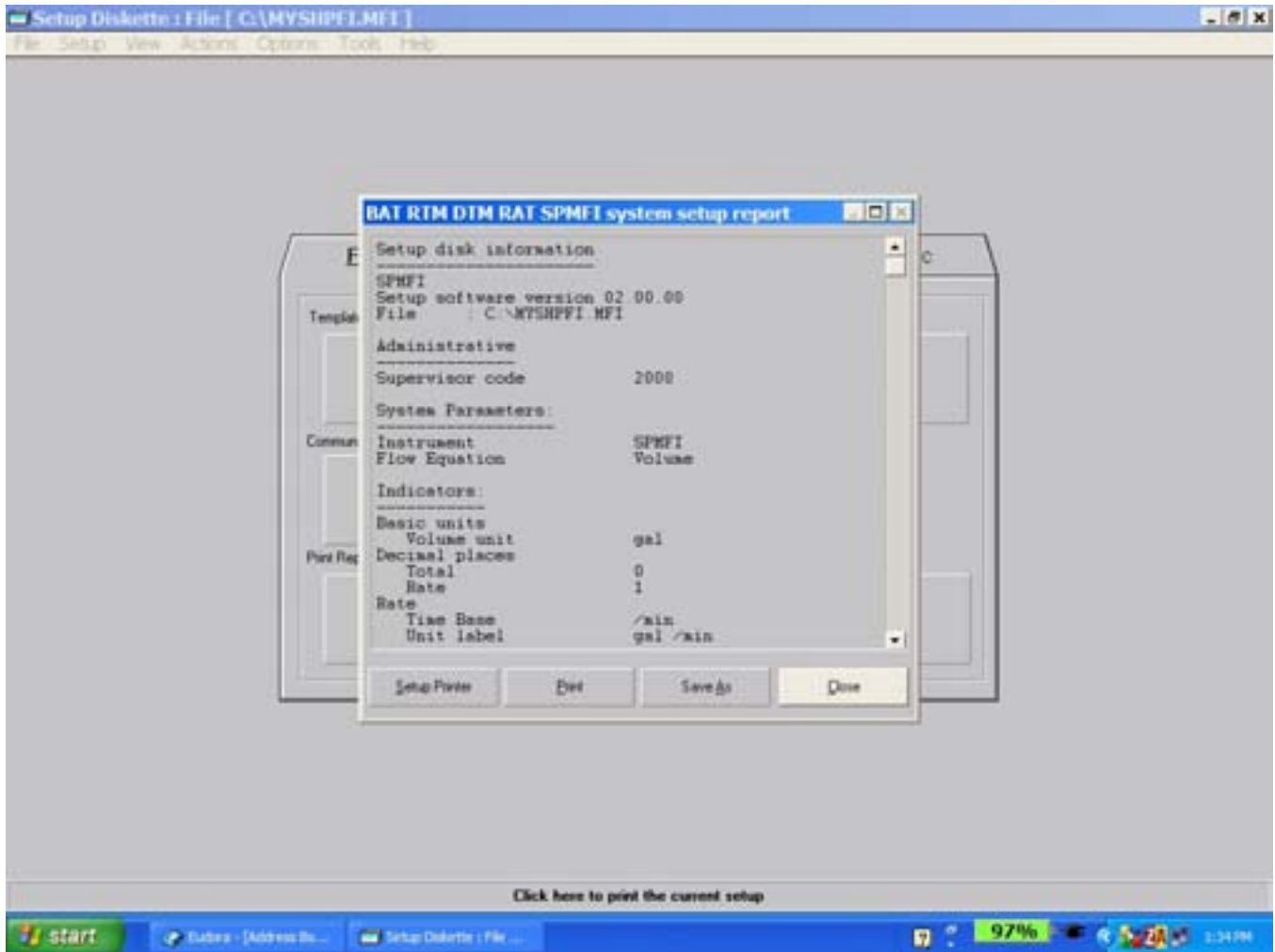

Step-8 - Download Configuration to SHPFI

Configuring your communication settings so you can download the configuration into the SHPFI is done by entering the desired value on the Setup control called Serial Usage. You must select the Port number that corresponds to your RS232 port on your PC. Use the default baud rate of 9600, parity of NONE settings since these are the factory default values used by the SHPFI. Click OK when done. On the file tab press Download, then START to begin the download sequence. Errors in download will be noted in the region provided.

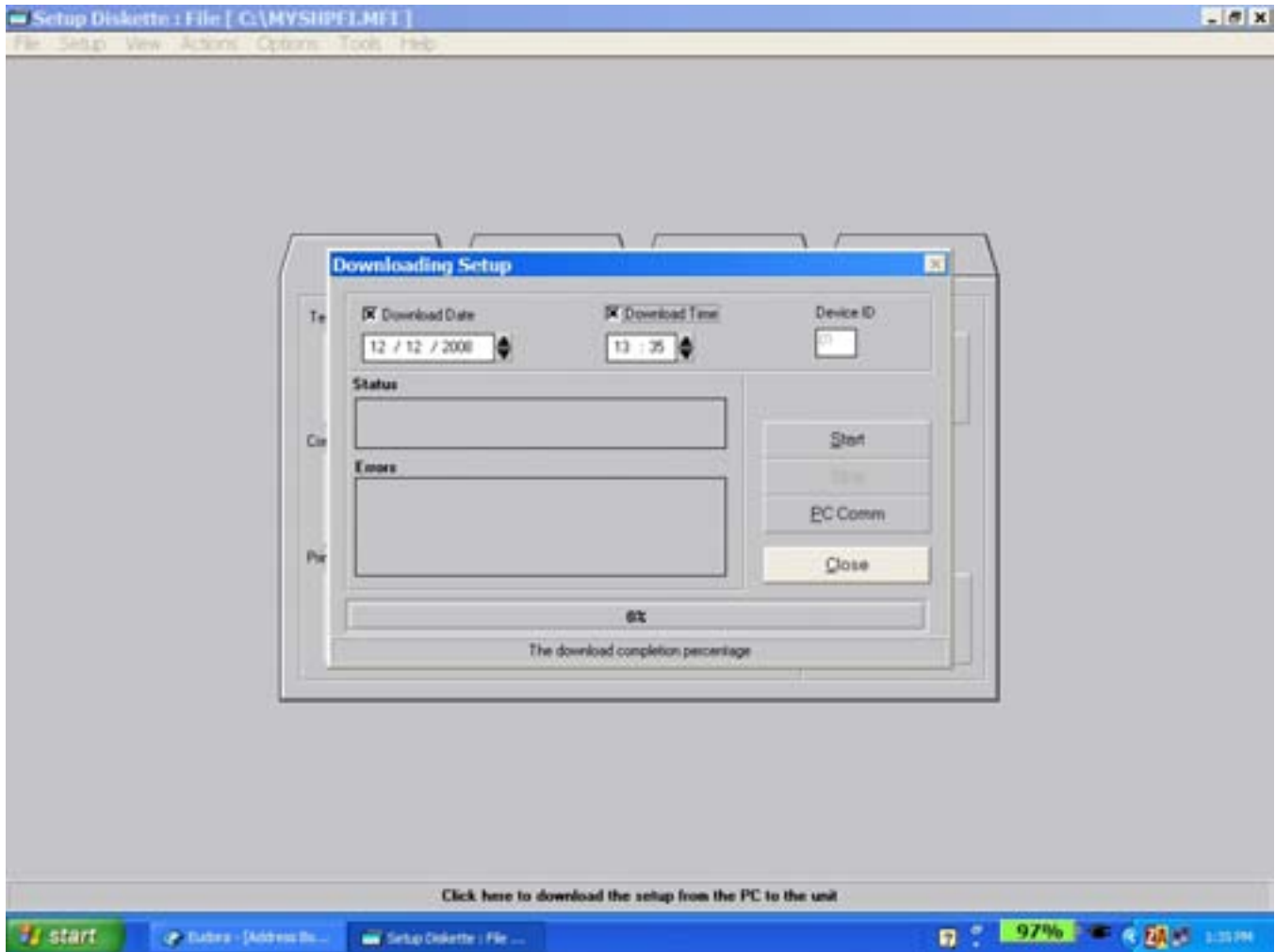

Step 9 - Save Configuration File

Saving the configuration on your PC is done by pressing the SAVE AS control on the file tab. Use a unique file name for each instrument you configure and organize your folders so they can be located at a future date if needed.

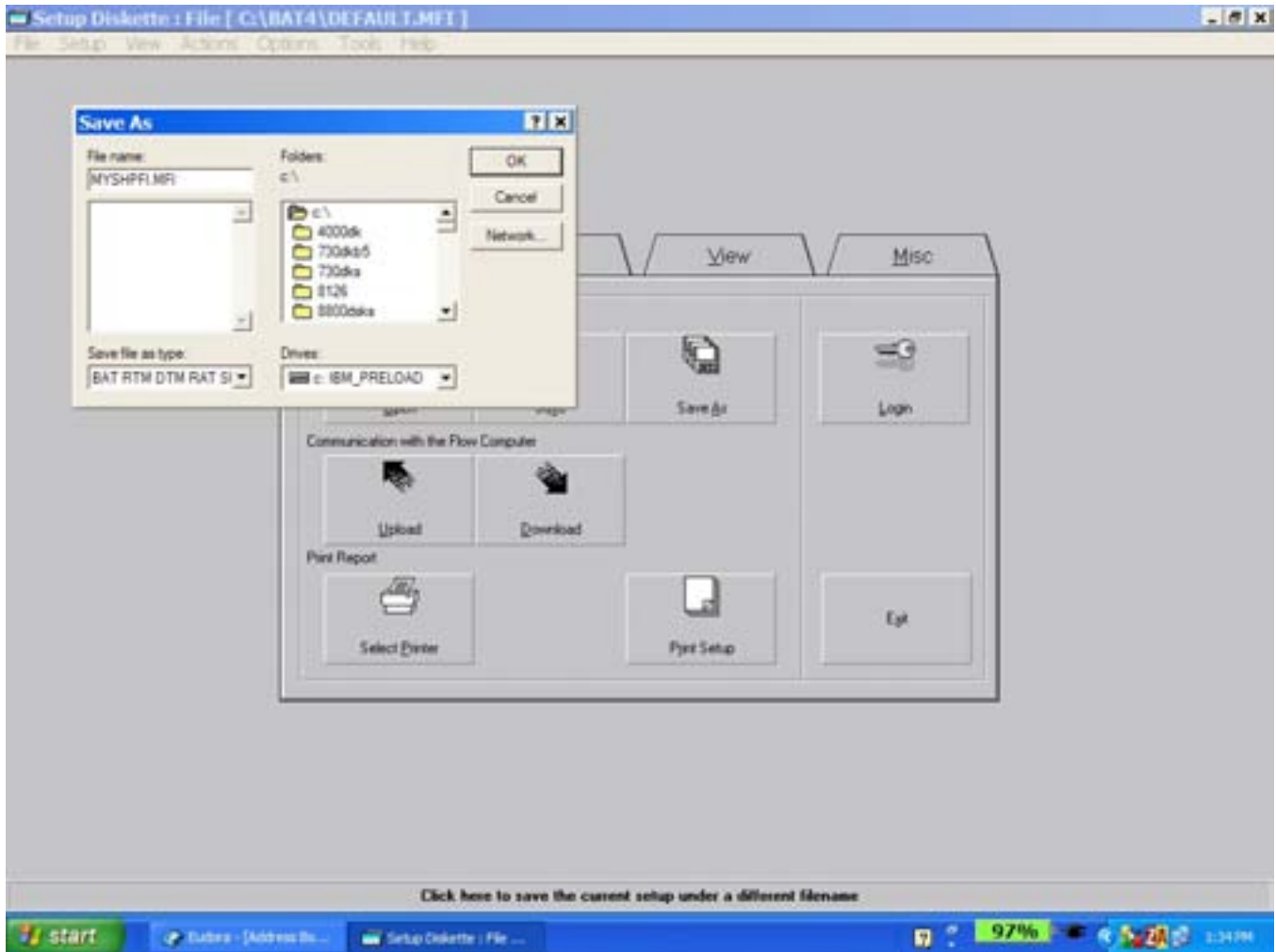

Step 10 - Viewing Computed Rate and Total

You can view the computed rate and total by selecting the VIEW tab, clicking the items you want to view then clicking start. The values will appear in the region provided as the PC gathers them from the SHPFI. When you are satisfied with the computed value press STOP.

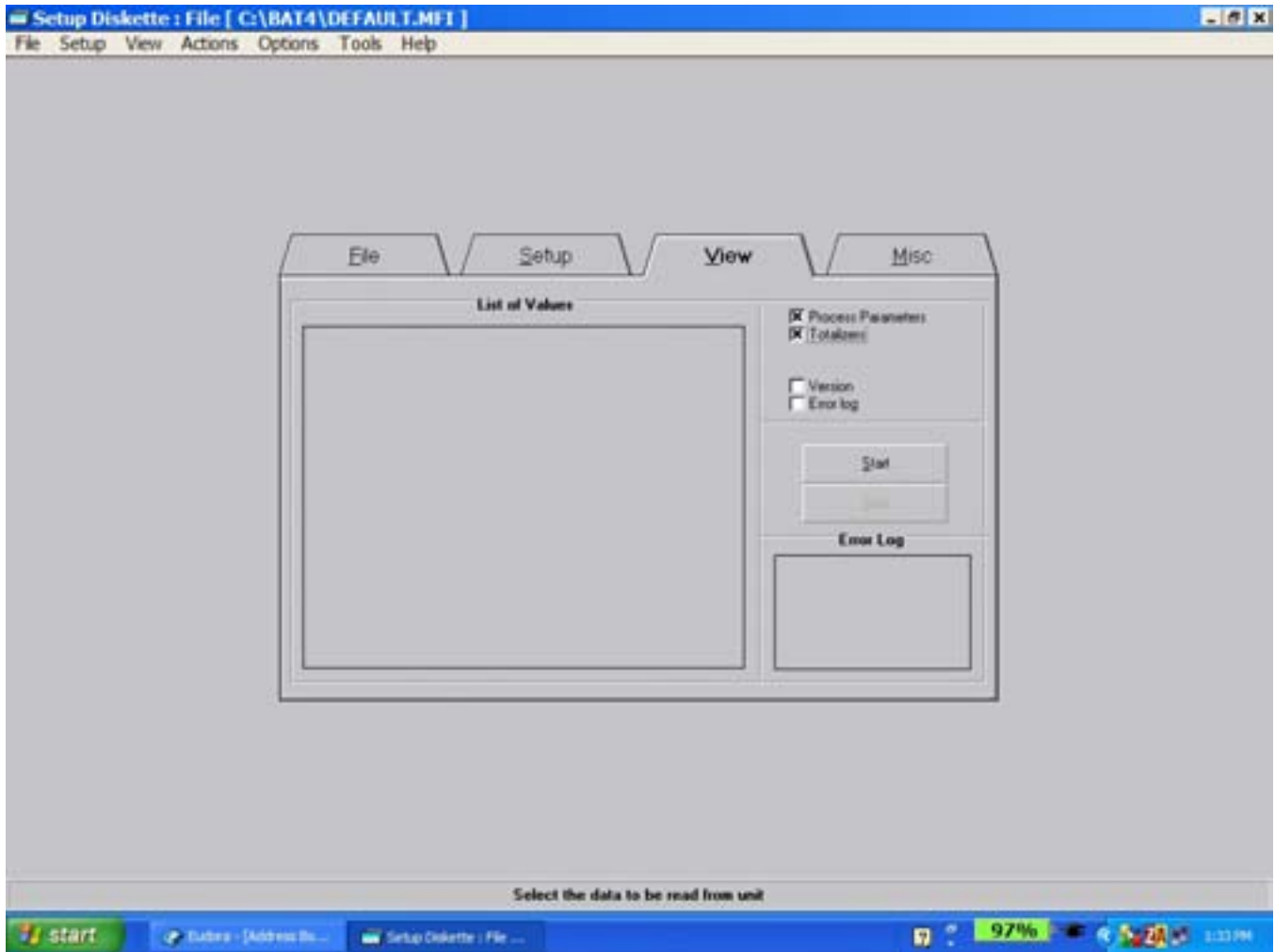

The unit is now ready for use. On the file tab press EXIT to end the session. Turn the power supply off. Disconnect the BSAC1 and install the field wiring to the flow sensor and receiving equipment.

Operation

A suitable pulse producing device or flow meter is wired to one of the three pulse inputs provided on the SHPFI. Only one of these inputs is used in a given application. There are no connections to the two unused pulse inputs.

Isolated magnetic pickups may be connected to terminals 1 and 2. Isolated contact closures may be connected to terminals 5 and 6. Any high level, DC pulse type may be connected to terminals 9(-) and 10(+).

Power to the unit is provided by the current loop.

Once properly wired, the operation of the SHPFI is automatic.

The internal flow totalizer is updated 8 times per second.

The internal flow total may be cleared using the setup program.

The flow rate computation occurs 8 times per second.

If the input pulses are not detected within the delay setting (0.1 to 99.9 seconds), an internal flow rate of 0 will be computed.

The analog output will be scaled based on the user selected zero and full scale and the computed internal flow rate. The analog output is updated at the same time as the internal rate.

The pulse output updates at the same rate as the internal totalizer in accordance with the setup of pulse scaling.

Analog Output Calibration

CAUTION: Performing the analog output calibration will erase all programming values. Please record all programmed values before beginning the analog output calibration

The 4-20 mA has been accurately set to 4.000 and 20.000 mA by the factory. No calibration should be required.

The 4-20 mA output may be verified periodically by installing a digital milliamp meter(DMM) in series with the analog output and simulating a full scale or over range flow rate.

If the output is out of calibration, perform the following using the Setup Software:

Connect a DMM set to read current in series with a power supply (8.5 to 30 volts DC) to TB12 (+) and TB11 (-). The output should read 4.000 ma (± 0.005). If it does not, Adjust the numbers on the display up or down until the output reads 4.000 ma (± 0.005). The DMM should now read 20.000 ma (± 0.005). If it does not, Adjust the numbers on the display up or down until the output reads 20.000 ma (± 0.005). Click "Close" and the unit will return to the "RUN" mode.

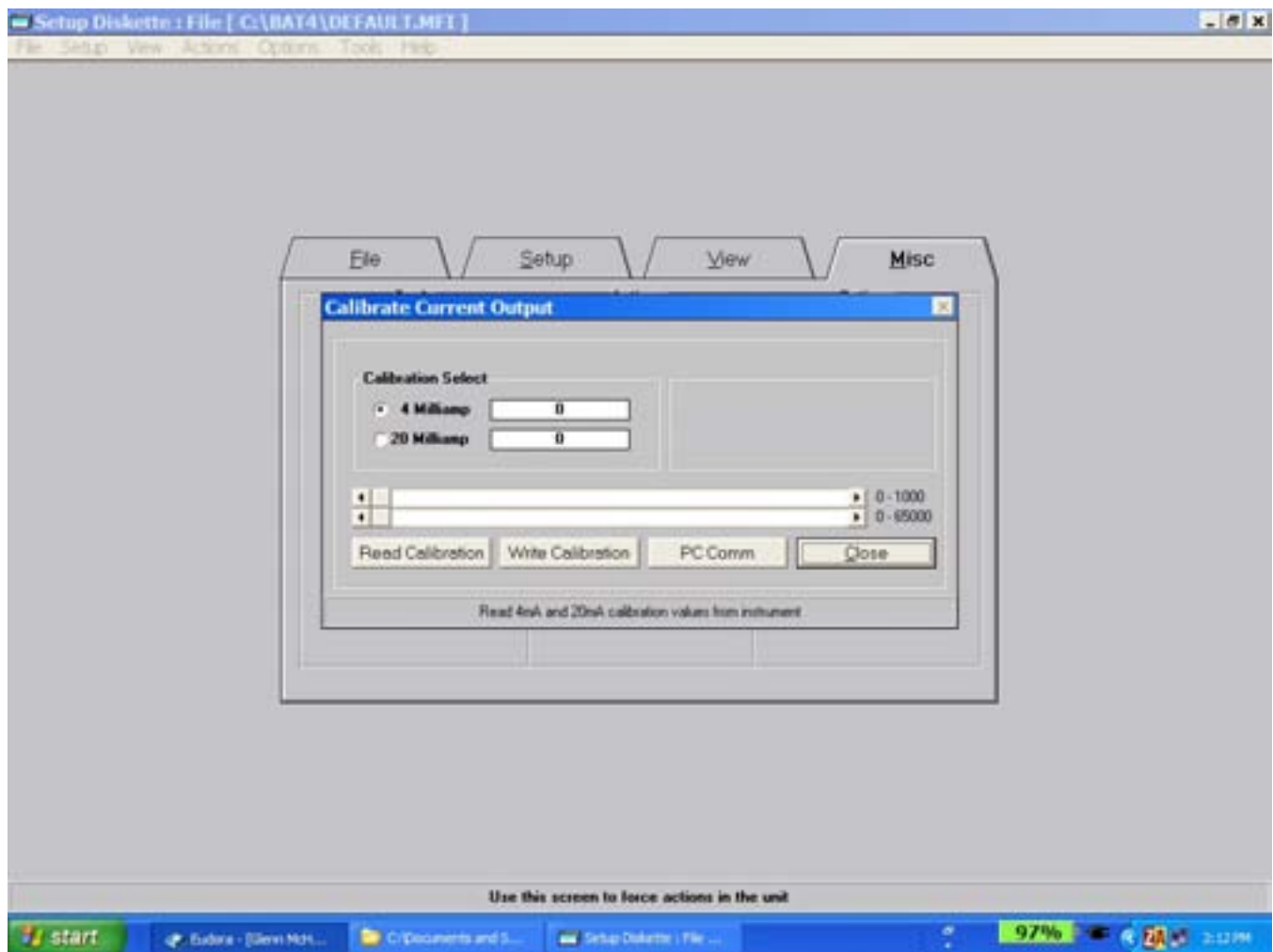

Decoding Part Number:

Ordering Information

EXAMPLE: SHPFI-M 2 HF2 ET

Series: _____

Mounting: _____

- 0 = OEM
- 2 = NEMA 4X Box
- 3 = Explosion Proof Housing

Mounting Options for NEMA 4X: _____

- H2 = 0.875" Hole for NEMA4X mounting style
- HF2 = 0.5" Female NPT Hub fitting for NEMA4X mounting style
- H3 = 1.125" Hole for NEMA4X mounting style
- HF3 = 3/4" Female NPT Hub fitting for NEMA4X mounting style

Additional conduit entry configurations are available, consult factory.

Options (Multiple Options Available) _____

- ET = Extended Temp.: -22°F to 158°F (-30°C to 70°C)
- CE** = CE Compliant
- CSA** = CSA Listed Explosion Proof (planned)
- IS** = UL Listed IS (planned)

Accessories:

- 115-24 = 115 VAC to 24 VDC power supply
- BSAC1 = RS232 Serial Adapter Cable (for programming only) with setup software. For use with S1 option.
- TFM-MK -1 = Turbine Flow meter Mounting Kit for flow meters with a 1" Male NPT riser
- TFM-MK -3/4 = Turbine Flow meter Mounting Kit for flow meters with a 3/4" Male NPT riser
- CA-TM-2-18-FL = 18" Turbine Flow meter Cable Assembly

Warranty

This product (excluding batteries) is warranted against defects in materials and workmanship for a period of two (2) years from the date of shipment to Buyer.

The Warranty is limited to repair or replacement of the defective unit at the option of the manufacturer. This warranty is void if the product has been altered, misused, dismantled, or otherwise abused.

ALL OTHER WARRANTIES, EXPRESSED OR IMPLIED, ARE EXCLUDED, INCLUDING BUT NOT LIMITED TO THE IMPLIED WARRANTIES OF MERCHANTABILITY AND FITNESS FOR A PARTICULAR PURPOSE.