



30:1 ULTRA WIDE-RANGE IR THERMOMETER WITH “K” PORT

USER'S MANUAL



IRT730K

Please read this manual carefully and thoroughly before using this product.

TABLE OF CONTENTS

Introduction	2
Key Features	3
Safety Instructions	3
What's in the Package	4
Product Overview	4 – 5
Setup Instructions	5
Install Battery	5
Operating Instructions	6 – 10
Using the IRT to Measure Temperature	6 – 7
Choosing an IRT Display Mode	7 – 8
Adjusting Emissivity and Setting Temperature Alarms	8 – 9
Recalling Stored Readings	9 – 10
Using the “K” Type Probe to Measure Temperature	10
Specifications	11
Operating & Maintenance Tips	11 – 12
Warranty Information	12
Return for Repair Policy	13
Appendix I. How to Make Accurate IR Temperature Measurements ..	13 – 14
Appendix II. Emissivities of Common Materials	15

INTRODUCTION

Thank you for purchasing General Tools & Instruments' (General's) IRT730K 30:1 Ultra Wide-Range IR Thermometer with “K” Port. Please read this manual carefully and thoroughly before using the thermometer.

The IRT730K measures surface temperature using either of two methods: non-contact (using an IR thermometer with a laser pointer) or contact (using a “K” type thermocouple). A “K” type bead thermocouple with a measurement range of -4° to 500°F (-20° to 260°C) is included in the package. Non-contact measurements made by the IRT can be adjusted for the emissivity of the surface, increasing the accuracy of readings.

The instrument automatically stores (records) up to 100 temperature readings in nonvolatile memory for later recall. During a single scanning session, the IRT730K simultaneously displays real-time measurements on a primary (larger) readout and the maximum, minimum or average measurement, or the largest difference between measurements, during that session on a secondary (smaller) readout.

The IRT730K, the “K” type bead thermocouple, a “9V” battery and this user's manual are packaged in a soft pouch inside a box.

KEY FEATURES

- Extremely wide measurement range
- Adjustable emissivity
- Laser targeting ring outlines analysis area
- Port for included “K” type bead thermocouple probe or another “K” type probe
- Releasing trigger holds measurement
- Automatically stores last 100 readings for recall
- Min/Max/Avg/Dif displays
- Adjustable Hi and Lo temperature alarm setpoints
- Large backlit LCD w/dual 4-digit readouts
- Auto power off
- °C/°F and laser on/off buttons
- Low battery indicator
- 3-year limited warranty

SAFETY INSTRUCTIONS

CAUTION!

The IRT730K is a Class 2 laser product that emits less than 1mW of radiation at a wavelength between 630 and 670nm. Avoid looking directly at the laser pointer. U.S. law prohibits pointing a laser beam at aircraft; doing so is punishable by a fine of up to \$10,000 and imprisonment.

The laser may cause discomfort if viewed directly. Your eyes' natural aversion reflex will prevent you from looking at the beam long enough to cause harm. As a precaution, keep the IRT730K out of the hands of children, especially if you have pets.

Never stare at the laser beam through binoculars or a magnifying glass.

Do not operate the IRT in the presence of flammable or explosive gases or in environments full of dust or static electricity.

Do not operate the unit near a source of a strong electromagnetic field, such as an arc welder or an induction heater.

Be careful not to burn yourself when attaching the bead thermocouple probe to a hot surface.

WHAT'S IN THE PACKAGE

The IRT730K comes in a soft pouch inside a box along with a “K” type bead thermocouple probe, a “9V” battery and this user’s manual.

PRODUCT OVERVIEW

Fig. 1 shows all controls, indicators, connectors and other physical features of the IRT730K. Fig. 2 shows all possible indications on the unit’s LCD. Familiarize yourself with the positions of all controls and connectors and the meaning of all display indications and icons before moving on to the Setup Instructions and Operating Instructions.



Fig. 1. All controls, indicators, connectors and other physical features of the IRT730K

General Tools & Instruments
75 Seaview Drive, Secaucus, NJ 07094
Made in China Manufactured |MM/YYYY

Complies with 21 CFR 1040.10 and 1040.11
except for deviations pursuant to Laser Notice
No. 50, dated June 24, 2007.

Laser radiation!
Do not stare into beam!
P_{max}<1mW, λ=650nm
Class 2 Laser Product
IEC60825-1 ed2 2007

1. Scanning indication (flashes)
2. Emissivity setting
3. Laser pointer on
4. Backlight on
5. Operating in continuous measurement mode (not used)
6. Selected temperature unit
7. Difference value on secondary readout
8. Average value on secondary readout
9. Minimum value on secondary readout
10. Secondary readout
11. Low battery icon
12. Low alarm setpoint
13. Low alarm activated
14. High alarm activated
15. High alarm setpoint
16. “K” type probe reading on secondary readout
17. Minimum value on secondary readout
18. Automatically storing readings
19. Primary readout
20. Held reading on primary readout

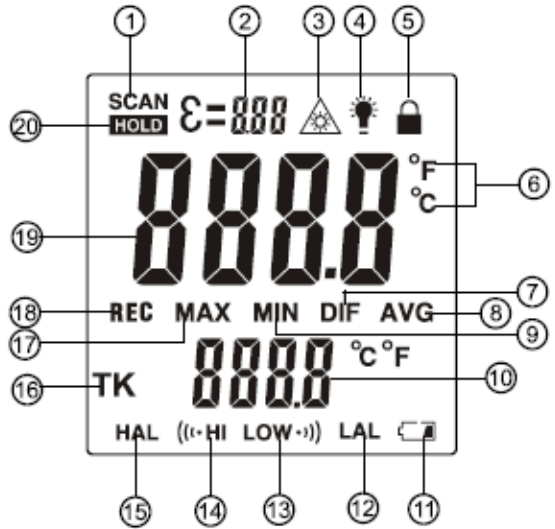

Fig. 2. All possible display indications

SETUP INSTRUCTIONS

INSTALL BATTERY

The IRT730K's battery compartment (Fig. 1, Callout 4) is below the measurement trigger and accessible from the front of the grip. Before installing the “9V” battery included in the package, remove the plastic wrap covering its terminals.

To install the battery:

1. Open the battery compartment by placing your thumb and forefinger in the indentations on the sides of the grip and pulling the top of the hinged compartment forward.
2. Plug the “9V” battery into the wired socket inside the compartment. The terminals of the battery and the socket mate in only one way, with the smaller male terminal plugging into the larger female terminal.
3. Close the battery compartment cover by pushing its top against the grip until the cover snaps shut.

OPERATING INSTRUCTIONS





USING THE IRT TO MEASURE TEMPERATURE





This section describes how to operate the IRT730K in its “normal” mode, with and without use of the backlight and/or laser pointer. In this mode (called **REC** mode), each measurement made by squeezing the measurement trigger is automatically stored (recorded) in a numerically tagged location in the instrument’s nonvolatile memory. After 100 measurements are stored, the 101st measurement made overwrites (erases) the first one. The section also explains how to change the factory default temperature unit from °F to °C.

1. Carefully remove the protective plastic film covering the LCD.
2. **Power on the IRT730K** by squeezing and holding the yellow measurement trigger (Fig. 1, Callout 3) while pointing the unit anywhere. The LCD and its gray backlight will illuminate and the laser pointer will activate. (If none of these three things happen, the IRT’s battery is dead and must be replaced; see p. 5 for instructions.) Note that squeezing the trigger causes the word **SCAN** (Fig. 2, Callout 1) to appear, flashing, in the upper left corner of the LCD.
3. **Release the trigger.** The following events will occur in a rapid-fire sequence:
 - I. The unit will “chirp.”
 - II. The word **SCAN** will disappear and be replaced by the word **HOLD** just below it.
 - III. The measured temperature will appear on the primary (large) readout in °F, with the text **REC** at its lower left. **REC** indicates that the measurement is about to be automatically stored (recorded) in the IRT730K’s nonvolatile memory.
 - IV. The measured temperature will also appear on the secondary (smaller) readout, following the brief appearance of a two-digit number. If this is the IRT’s first measurement, that number will be **01**. The number represents the measurement’s memory storage location.
4. **Squeeze and hold the trigger again** while pointing the IRT at a different target. Then release the trigger. As before, the unit will chirp and **SCAN** will be replaced by **HOLD**. The temperature of the second target will again appear on both the primary and secondary readouts. This time, however, note that the second reading will be accompanied by the brief appearance of the memory tag **02** on the secondary readout.
5. **Squeeze and hold the trigger again** and then release it. The same sequence of events will occur, with the new reading tagged **03** in memory. Allow 30 seconds to pass. After 30 seconds, the IRT’s Auto Power Off (APO) function will activate and cause the unit to shut down silently.

To change the measurement unit from the factory default °F to °C, press the **MODE** button (Fig. 1, Callout 7) once briefly while operating in **REC** mode. **REC** will be replaced by **MAX** in the middle of the LCD. Then press the °C/°F button (Fig. 1, Callout 8). This will convert the Fahrenheit readings on both readouts to the corresponding Celsius values.

To return to operation in **REC** mode, press the **MODE** button seven times with **MAX** on-screen. **REC** will replace **MAX**. The next section of the manual explains how to switch to operation in the IRT730K’s six display modes other than **REC** and **MAX**.

To turn off the laser pointer, press the  /  button (Fig. 1, Callout 6) while squeezing and holding the measurement trigger. The  icon (Fig. 1, Callout 3) will disappear from the top row of the LCD. To re-enable the laser pointer, press the  /  button while squeezing and holding the measurement trigger.

To disable the LCD backlight, press the  /  button while the unit is powered on but *not* operating in scanning mode (i.e., the trigger has been released to replace **SCAN** by **HOLD**). The  icon will disappear from the top line of the LCD. To re-enable the backlight, press the  /  button again while the unit is powered on and *not* operating in **SCAN** mode.

CHOOSING AN IRT DISPLAY MODE

Because the IRT730K automatically records and tags every measurement it makes, it can analyze the set of readings made and stored over any finite period of time. Often, the period that provides the most useful information is the measurement session—the time during which you measure the temperature of multiple objects or surfaces. The session begins when you squeeze the trigger to “wake up” the IRT; it typically ends 30 seconds after you have finished making measurements with the activation of the APO function.

What the IRT730K can do is display the maximum and minimum temperatures recorded during a measurement session. It can even calculate and display the average reading and the difference between the highest and lowest readings. The value of being able to quickly determine the hottest or coldest object of a group, or the difference between their temperatures, should be obvious.

These four display modes—**MAX**, **MIN**, **AVG** and **DIF**—can be entered from **REC** mode by pressing the **MODE** button the correct number of times. The currently selected display mode is indicated by its three-letter abbreviation in the middle of the display. The value of that parameter—the session’s maximum, minimum or average temperature, or the difference between the hottest and coldest temperature—is shown on the secondary readout.

The IRT730K also can display three other parameters:

- The temperature of an object or surface touched by the included “K” type bead thermocouple probe or any other “K” type probe. This temperature is identified by the two-letter abbreviation **TK**. See p. 10 to learn how to use the external temperature probe.
- The high and low temperature alarm setpoints **HAL** and **LAL**. Each can be set to any integral value from -58° to 1472°F (-50° to 800°C)—the measurement range of the IRT730K. The factory preset value for **HAL** is 1472°F (800°C)—the highest temperature that the unit can measure. The factory value for **LAL** is -58°F (50°C)—the lowest temperature that the unit can measure.

By default, when the unit powers on in response to your squeezing the trigger, the unit resumes operation in the same display mode it was in when the APO function powered the IRT off. To change the display mode, you use the **MODE** button to cycle through an eight-step sequence comprising the five display modes (**REC**, **MAX**, **MIN**, **AVG** and **DIF**) plus **TK** and the two alarm setpoints **HAL** and **LAL**, as shown in the figure on the next page.

To move from one display mode to the next in the sequence, briefly press (but do not hold) the **MODE** button.

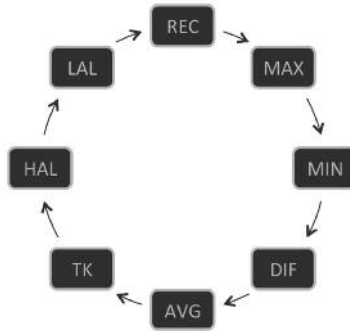

ADJUSTING EMISSIVITY AND SETTING TEMPERATURE ALARMS

The IRT730K has three parameters that you can set anywhere over a predefined range:

1. **Emissivity (ϵ)**—the ability of an object to reflect or absorb IR radiation (energy)—can be assigned any value between 0.10 and 1.00 in steps of 0.01. The default (factory setting) of ϵ is 0.95. Because the IRT730K measures the amount of infrared energy emitted by a surface, its measurements are most accurate when they take into account the characteristic emissivity of the target material.

A perfectly absorbent surface (called a black body) has an emissivity of 1; it absorbs 100% of the thermal energy hitting it. An object with an emissivity of 0.8 absorbs 80% of IR energy and reflects 20% of it. All emissivity values fall between 0 and 1; as a rule, the shinier the surface, the lower its emissivity.

To maximize the accuracy of IRT730K measurements, you should enter the actual emissivity of the target surface (see Appendix II) using the instrument's three buttons and the procedure below. Compensating for emissivity will particularly improve the accuracy of measurements of surfaces with emissivities nearer to zero than to the default IRT730K setting of 0.95.

2. **High Temperature Alarm (HAL)**. As mentioned earlier, the **HAL** setpoint can be set to any integral temperature value from -58° to 1472°F (-50° to 800°C)—the operating range of the IRT730K.
3. **Low Temperature Alarm (LAL)**. The **LAL** setpoint also can be set to any integral temperature value from -58° to 1472°F (-50° to 800°C)—the operating range of the instrument.

The presetting of the high and low temperature alarms to the high and low limits of the instrument's measurement range is a convenience. If you never change the value of **HAL** or **LAL** (because you choose not to use temperature alarms) from its default value, you will never be bothered by an alarm inadvertently sounding because you forgot to reset an alarm threshold. Neither alarm can be disarmed.

The High Temperature Alarm is activated when the temperature measured by the IRT is higher than the **HAL** setpoint. The Low Temperature Alarm is activated when the temperature measured by the IRT is lower than the **LAL** setpoint. In each case, the IRT730K responds by sounding a second chirp (following the usual first chirp to indicate that a measurement was made and stored) and flashing an icon on the bottom line of the LCD (Fig. 2, Callouts 13 and 14). The second chirp is the only audible indication that a temperature alarm has been activated.

To change the unit's emissivity setting and either alarm threshold, press and hold the MODE button with the instrument powered on and operating in any mode.

Whatever the operating mode, pressing and holding the **MODE** button will cause the emissivity icon ϵ (Fig. 2, Callout 2) on the top line of the LCD to begin flashing. You now have 30 seconds to change the emissivity value before the APO function activates. You can change ϵ in 0.01 steps by pressing either the **°C/°F** button to decrease the value or the \blacktriangle / \blackstar button to increase the value. To move up or down quickly, press and hold either button.

With ϵ flashing, pressing the **MODE** button briefly saves the currently displayed value (whether or not you have adjusted it) and changes the adjustment target to **HAL**. Pressing the **MODE** button causes **HAL** to begin flashing on the bottom left of the LCD. Once **HAL** begins flashing, you have 30 seconds to adjust its value up or down to any temperature within the unit's measurement range. Press the **°C/°F** button to decrease the value or the \blacktriangle / \blackstar button to increase it. To move up or down quickly, press and hold the corresponding button.

Pressing the **MODE** button briefly with **HAL** flashing saves the currently displayed value and changes the adjustment target to **LAL**. Pressing the **MODE** button causes **LAL** to begin flashing on the bottom right of the LCD. Once **LAL** begins to flash, you have 30 seconds to adjust its value up or down to any temperature within the unit's measurement range. As before, press the **°C/°F** button to decrease the value or the \blacktriangle / \blackstar button to increase it. To move up or down quickly, press and hold the corresponding button.

Pressing the **MODE** button with **LAL** flashing returns the three-step sequence to its starting point—with ϵ flashing on the top line. The figure below shows the sequence in graphic form.

Be aware that, unlike values shown on the primary and secondary readouts (all of which have 0.1° resolution), **LAL** and **HAL** only have 1° resolution. In other words, do not mistake the default value of **HAL** (1472°F) for 147.2°F.

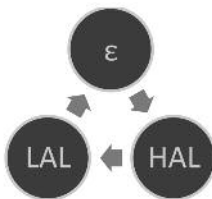





RECALLING STORED READINGS

To recall the measurements made and automatically saved by the IRT730K during operation in **REC** mode:

1. Power on the unit by squeezing the measurement trigger.
2. Release the trigger to exit **SCAN** mode. Doing so automatically stores the current IRT measurement in memory. For the purpose of illustrating how stored measurements are numerically tagged, assume that this reading is given the memory tag **83**.

3. Press the **MODE** button as many times as necessary to enter **REC** mode. At this point, the values on the primary and secondary displays will be identical.
4. To recall the value stored just prior to the measurement that was just stored (with tag **83**), press the **°C/°F** button once. The number **82** will appear briefly (for less than a second) on the secondary display, followed by the value of the measurement stored with tag **82**.
5. Press the **°C/°F** button again and **82** will be briefly replaced by **81**, followed by the value of the measurement stored with tag **81**.

As you can see, by pressing the **°C/°F** button repeatedly you can recall all stored IRT measurements in reverse chronological order (newest through oldest). By pressing the  /  button, you can recall stored IRT measurements in chronological order (oldest through newest). However, unless you have kept track of which tags have been assigned to particular measurements, you typically will recall readings stored long ago. For example, pressing the  /  button instead of the **°C/°F** button in Step 4 above would recall tag **84**, followed by the temperature associated with it. That value, and the values associated with tags **85** and **86**, would likely be irrelevant because they represent measurements made nearly 100 hundred trigger squeezes ago.

USING THE “K” TYPE PROBE TO MEASURE TEMPERATURE

To measure the temperature of a surface using the included “K” type thermocouple probe (or another “K” type probe):

- 1) Plug the two prongs of the probe into the two slots on the bottom of the IRT730K. Be sure to insert the slightly narrower (+) prong into the slightly narrower slot, which is closer to the rear of the unit.
- 2) Press the **MODE** button as many times as necessary to make **TK** appear to the left of the secondary display.
- 3) Attach the end of the probe to the surface whose temperature you wish to measure.
- 4) Squeeze and release the measurement trigger. The temperature measured by the thermocouple probe will appear on the secondary readout.

Unlike measurements made by the IRT, measurements made by the “K” type probe are not stored in memory. And although the temperature measured by the IRT will simultaneously appear on the primary readout after you release the measurement trigger, it will not be stored in memory—because the IRT730K is not operating in **REC** mode.

If you allow the IRT730K’s APO function to activate with the unit operating in **TK** mode, when you power the unit back on it will resume operation in **TK** mode.

SPECIFICATIONS

IRT Distance to Spot (D:S) Ratio	30:1
IRT Measurement Range	-58° to 1472°F (-50° to 800°C)
IRT Measurement Accuracy	±7.2°F (4°C) from -58° to 32°F (-50° to 0°C); ±1.5% of reading or ±3.6°F (2°C), whichever is greater, from 32° to 752°F (0° to 400°C); ±2% of reading or ±3.6°F (2°C), whichever is greater, from 752° to 1472°F (400° to 800°C)
IRT Measurement Resolution	0.1° (F or C) below 1000°; 1° above 1000°
IRT Emissivity	Adjustable from 0.1 to 1.0 in 0.01 steps with default of 0.95
“K” Port Measurement Range:	-40° to 2372°F (-40° to 1300°C)
Range of Included Probe	-4° to 500°F (-20° to 260°C)
Accuracy of Included Probe	±(2% + 2 digits)
Response Time	<500ms
Laser Power	<1mW (Class 2) @ wavelength of 630 to 670nm
Spectral Response	8 to 14 um
Operating Temperature	32° to 122°F (0° to 50°C) @10 to 90%RH
Auto Power Off Trigger	30 seconds of front-panel inactivity
Dimensions	7.6 x 3.8 x 3.3 in. (192 x 95 x 83mm)
Weight	9.7 oz. (275g)
Power Source	1 “9V” battery (included)

OPERATING & MAINTENANCE TIPS

All IR thermometers, including the IRT730K, take the average temperature of all objects within a circular target area. Depending on the distance to the target, the target area may include both the target and background objects in the thermometer’s field of view. If background objects in the field of view are cooler than the target, the measured temperature will be lower than the target’s actual temperature. If background objects are hotter than the target, the measured temperature will be higher than the target’s actual temperature. The IRT730K’s large D:S ratio of 30:1 enables narrow measurement of high-temperature objects (up to 1472°F/800°C) from a safe distance.

To eliminate measurement error, move the IRT730K close enough to the target so the circle created by the targeting laser falls just within the object being measured. See Appendix II for a brief tutorial: How to Make Accurate IR Temperature Measurements.

When the Low Battery icon appears at the lower right of the LCD (Fig. 2, Callout 11), it’s time to change the “9V” battery that powers the IRT (although measurements will remain valid for several hours after the icon first appears). To change the battery, follow the instructions on p. 5.

If the temperature of the IRT's target is higher than 1472°F (800°C)—the upper limit of the unit's measurement range—or lower than -58°F (-50°C)—the lower limit of the measurement range—"OL" will appear on the main readout.

The IRT730K cannot make accurate measurements if there is glass or plastic between it and the target.

Clean the lens of the infrared sensor lens (Fig. 1, Callout 2) often—but never use a solvent.

Abrupt temperature changes will cause condensation and possible vapor penetration. Clean the LCD after the vapor evaporates. Blow off loose particles with clean, compressed air. Gently brush remaining debris away with a lens hair brush.

To clean the housing, use a moist cotton swab or wet sponge. Avoid excessive amounts of water and corrosive gas or liquids.

Remove the battery if you do not expect to use the IRT for an extended period of time (months or years).

Do not drop or disassemble the unit or immerse it in water.

WARRANTY INFORMATION

General Tools & Instruments' (General's) IRT730K 30:1 Ultra Wide-Range IR Thermometer with "K" Port is warranted to the original purchaser to be free from defects in material and workmanship for a period of three years. Subject to certain restrictions, General will repair or replace this instrument if, after examination, the company determines it to be defective in material or workmanship. The warranty period begins on the date of purchase. You are encouraged to register your product online. General will extend your warranty an additional 60 days if you register at www.generaltools.com/ProductRegistry.

This warranty does not apply to damages that General determines to be from an attempted repair by non-authorized personnel or misuse, alterations, normal wear and tear, or accidental damage. The defective unit must be returned to General Tools & Instruments or to a General-authorized service center, freight prepaid and insured.

Acceptance of the exclusive repair and replacement remedies described herein is a condition of the contract for purchase of this product. In no event shall General be liable for any incidental, special, consequential or punitive damages, or for any cost, attorneys' fees, expenses, or losses alleged to be a consequence of damage due to failure of, or defect in any product including, but not limited to, any claims for loss of profits.

Register now at www.generaltools.com/ProductRegistry to receive a 60-day extension to your warranty.

RETURN FOR REPAIR POLICY

Every effort has been made to provide you with a reliable product of superior quality. However, in the event your instrument requires repair, please contact our Customer Service to obtain an RGA (Return Goods Authorization) number before forwarding the unit via prepaid freight to the attention of our Service Center at this address:

General Tools & Instruments
75 Seaview Drive
Secaucus, NJ 07094
212-431-6100

Remember to include a copy of your proof of purchase, your return address, and your phone number and/or e-mail address.

APPENDIX I

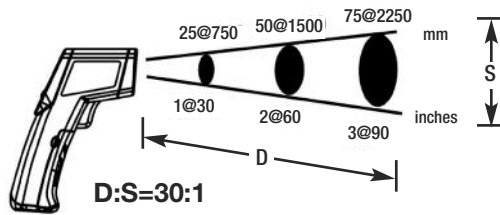

The IRT730K's field of view

HOW TO MAKE ACCURATE IR MEASUREMENTS

The IRT730K has a distance-to-spot (D:S) ratio of 30:1. This means that the target area (spot) whose infrared radiation (temperature) is being measured increases in diameter by 1 inch for every 30 inches you move *away* from the target. Conversely, the diameter of the target area measured decreases by 1 inch for every 30 inches you move *closer* to the target.

All IR thermometers (IRTs), including the IRT730K, take the *average* temperature of all objects within a circular *target area (spot)*. Although the distance “D” in the D:S ratio is defined as a linear value and the “S” defines the diameter of the spot (see above figure), the critical parameter is the *target area*. Depending on the distance to the target (the object whose temperature you want to measure), the target area may include both the target and background objects near or behind the thermometer’s field of view, which defines the target area or spot.

To explain the relationship between D:S ratio and measurement accuracy, consider how the IRT730K would be used to measure the temperature of a small AC motor suspected of overheating. The motor measures approximately 1 ft x 1 ft, so it has an area of 1 ft². If the IRT730K is used to make the measurement from 60 ft. away, the reading will have a large error. At this distance, the target area is 2 ft². Therefore, the IRT730K will measure not just the temperature of the motor, but also the temperature of the physical surroundings in its field of view, and average the two readings.

How inaccurate would the measurement be? If the motor's operating temperature is 200°F and the background temperature is 75°F, and the motor's area is half the target area at the measurement distance, the following equation gives the average temperature of the target area:

$$T_{avg} = (T_{motor} + T_{background}) \div 2$$

Solving for T_{avg} , we get $(200 + 75) \div 2$ or 137.5°F., which is what the IRT730K would display. In other words, trying to measure the temperature of the motor from 60 ft. away introduced an error of $(200-137.5) \div 200$, or 31% into the measurement. In this case, the measured temperature was 31% below the motor's actual temperature because the background is cooler than the motor.

To eliminate measurement error, the IRT must be moved close enough so the motor is the only object in the target area (see figure below). For a motor with an area of 1 ft² and using an IRT with a D:S ratio of 30:1, the optimum measurement distance would be 30 ft.

For best results, the targeted area (spot) should fall within the target's boundaries, as in the figure below.

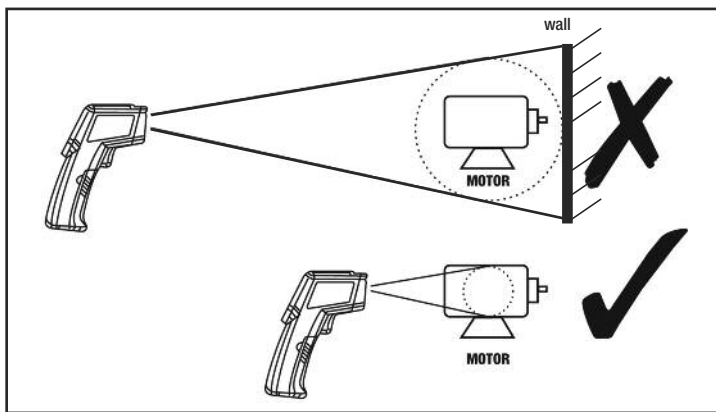

Measuring a motor's temperature from the wrong (top) and right (bottom) distance

APPENDIX II

EMISSIVITIES OF COMMON MATERIALS

Material	Emissivity	Material	Emissivity
Aluminum	0.30	Glass	0.90 to 0.95
Asphalt	0.95	Iron Oxides	0.78 to 0.82
Concrete	0.95	Paint	0.80 to 0.95
Asbestos	0.95	Plastic	0.85 to 0.95
Ceramics	0.95	Paper	0.70 to 0.94
Brass	0.50	Plaster	0.80 to 0.90
Brick	0.90	Rubber	0.95
Carbon	0.85	Wood	0.90
Sludge	0.94	Textile	0.94
Frozen Food	0.90	Lead	0.50
Hot Food	0.93	Marble	0.94
Ice	0.98	Cloth (black)	0.98
Snow	0.90	Sand	0.90
Human Skin	0.98	Water	0.93



Specialty Tools & Instruments

GENERAL TOOLS & INSTRUMENTS

75 Seaview Drive
Secaucus, NJ 07094-1806
PHONE (212) 431-6100
FAX (212) 431-6499
TOLL FREE (800) 697-8665
e-mail: sales@generaltools.com
www.generaltools.com
IRT730K User's Manual

Specifications subject to change without notice

©2015 GENERAL TOOLS & INSTRUMENTS

NOTICE - WE ARE NOT RESPONSIBLE FOR TYPOGRAPHICAL ERRORS.

MAN# IRT730K

5/26/15



General Tools & Instruments



GeneralToolsNYC