

EZiSYSTEM

User Manual

V 1.0



EN

DE

ES

FR

PL

RU

HU

IT

NL

DA

NO

SV

EZiSYSTEM

User Manual

Version 1.0
English



Introduction

Purchase

Congratulations on your purchase of a EZiSYSTEM instrument.



Product identification

This manual contains important safety directions as well as instructions for setting up the product and operating it. Refer to "9 Safety Directions" for further information. Read carefully through the User Manual before you switch on the product.





The model and the serial number of your product are indicated on the type plate. Enter the model and serial number in your manual and always refer to this information when you need to contact your agency or Cable Detection authorised service workshop.

Type: _____

Serial No.: _____

Symbols

The symbols used in this manual have the following meanings:

Type	Description
 Danger	Indicates an imminently hazardous situation which, if not avoided, will result in death or serious injury.
 Warning	Indicates a potentially hazardous situation or an unintended use which, if not avoided, could result in death or serious injury.
 Caution	Indicates a potentially hazardous situation or an unintended use which, if not avoided, may result in minor or moderate injury and/or appreciable material, financial and environmental damage.
	Important paragraphs which must be adhered to in practice as they enable the product to be used in a technically correct and efficient manner.

Validity of this manual

This manual applies to all EZiSYSTEM instruments, which are the i-Series. Differences between the various instruments and models are marked and described.

Table of Contents

In this manual	Chapter	Page
	1 General Information	7
	1.1 How to Use this Manual	7
	1.2 i-Series General Information	8
	1.3 i-Series Instruments and Accessories	10
	2 How to Use the Locator	11
	2.1 General Information	11
	2.2 Locator Overview	12
	2.3 Locator Setup and Information	14
	2.4 Hazard Zone	16
	2.5 How to Locate a Service	18
	2.6 Wireless Data Communication, where applicable	27
	3 How to Use the Transmitter	29
	3.1 General information	29
	3.2 Transmitter Overview	31
	3.3 How to Locate a Service Using the Transmitter	33
	4 How to Use the Conductive Rod	37
	4.1 General Information	37
	4.2 Conductive Rod Overview	37
	4.3 How to Locate a Service Using the Conductive Rod	38

5	How to Use the Signal Clamp	40
5.1	General Information	40
5.2	Signal Clamp Overview	40
5.3	How to Locate a Service Using the Signal Clamp	41
6	How to Use the Property Connection Set	43
6.1	General Information	43
6.2	Property Connection Set Overview	43
6.3	How to Locate a Service Using the Property Connection Set	44
7	How to Use the Sonde	46
7.1	General Information	46
7.2	Sonde Overview	46
7.3	How to Locate a Service Using the Sonde	49
8	Care and Transport	51
8.1	Transport	51
8.2	Storage	51
8.3	Cleaning and Drying	52
9	Safety Directions	53
9.1	General Introduction	53
9.2	Intended Use	53
9.3	Limits of Use	54
9.4	Responsibilities	54
9.5	Hazards of Use	55
9.6	Electromagnetic Compatibility EMC	59
9.7	FCC Statement, Applicable in U.S.	62

10	Technical Data	65
10.1	Locator i-Series Technical Data	65
10.2	Transmitter Technical Data	69
10.3	Conductive Rod Technical Data	72
10.4	Sonde Technical Data	74
10.5	Property Connection Set Technical Data	76
10.6	Signal Clamp Technical Data	78
11	International Limited Warranty	80
Appendix A	Functional Checks	81
A.1	Locator Functional Check	81
A.2	Transmitter Functional Check	85
A.3	Conductive Rod Functional Check	90
A.4	Sonde Functional Check	92
Appendix B	World Frequency Zones	95
Index		99

1

1.1



Naming convention

General Information

How to Use this Manual

It is recommended to set up the product while reading through this manual.

EZiCAT i500, EZiCAT i550 are hereinafter referred to as Locator.
Differences between the models are marked and described.

EZITRACE is hereinafter referred to as Transmitter.

EZiROD is hereinafter referred to as Conductive Rod.

Index

The index is at the back of the manual.

Instrument label

On the Locator and Transmitter you will find a label that shows some important information by means of illustrations. You will find some of these illustrations in this manual too. This should help to get a clear connection between the instrument label and the information in this manual.

1.2

i-Series General Information

Description

Locators are used to detect buried conductive services emitting an electromagnetic signal which is generated by a current passing through the service.

Transmitters are used to apply a distinct signal to conductive services, which may not radiate electromagnetic signals or may need to be traced for a specific purpose. The Transmitter is required to make a depth measurement.

The Locators and Transmitters described within this manual will greatly increase the detection process and help to reduce the dangers and costs associated with service strikes. But the very nature of electromagnetic location is dependent on the services being conductive (metallic) and radiating a signal as current flows through them.

It is important to remember that a Locator on its own will not detect all services and care should be taken when excavating. It is generally accepted that a safe system of work should be adopted which would include planning the work in advance, the use of utility maps, the use of Locators and Transmitters, and the use of safe digging practices.

Caution

The absence of a positive indication does not guarantee the non-existence of a service. Services without a detectable signal may be present.

The Locators can only locate non-metallic services such as plastic pipes, typically used by the water and gas utilities, with the use of appropriate accessories.

Precautions:

Always excavate with care.

Accessories

Designed to increase the detection of services with no (or little) signals on them. Generally work in conjunction with the Locator and Transmitter.

Functional Check

Designed to demonstrate the equipment is working satisfactorily in between service intervals. Refer to "Appendix A Functional Checks" for more information.

1.3

i-Series Instruments and Accessories

General information

The i-Series is a collection of products used to locate buried metallic and nonmetallic services.

i-Series instruments overview

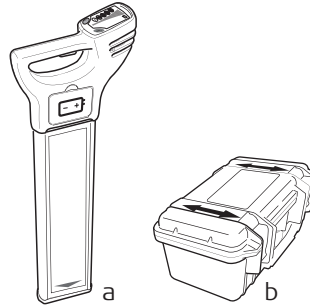

- a) Locator
- b) Transmitter

i-Series accessories overview

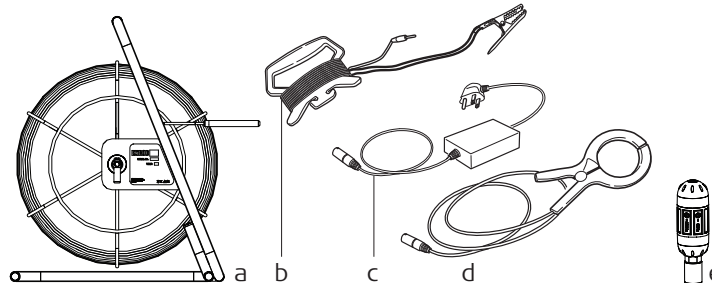

- a) Conductive Rod (non metallic service tracer)
- b) Extension Cable
- c) Property Connection Set
- d) Signal Clamp
- e) Sonde

2

How to Use the Locator

2.1

General Information

Operating modes

- Passive modes (Power and Radio)
 - Active modes (8 kHz and 33 kHz)
 - Auto mode (Combined Power and Radio modes)
-

Electromagnetic signals

An electromagnetic signal radiates from buried conductive services as an electrical current flows through them. The Locator processes these signals and displays their presence.

Passive signals

Some signals are already present on buried services and can be readily detected by the Locator. We call these passive signals. These signals are generated by power distribution systems and radio transmitters.

Active tracing

Some conductive services do not emit passive signals. These services may be traced by applying a signal to the service by using a transmitter.

Depth indication (i550 only)

Depth indication is only available with the i550 Locator used in conjunction with the Transmitter or Sonde. The displayed depth is to the centre of the service or to the Sonde.

Wireless communication (Bluetooth)

Data can be wirelessly transferred from the Bluetooth enabled Locator to devices which are designed to accept the information.

Hazard zone

Provides an additional alarm, indicating the close proximity of a service emitting a Power, 8 kHz or 33 kHz signal.

Peak hold

Assists in pinpointing a service by displaying the peak reading for a short period of time.

2.2

Locator Overview

Locator main parts

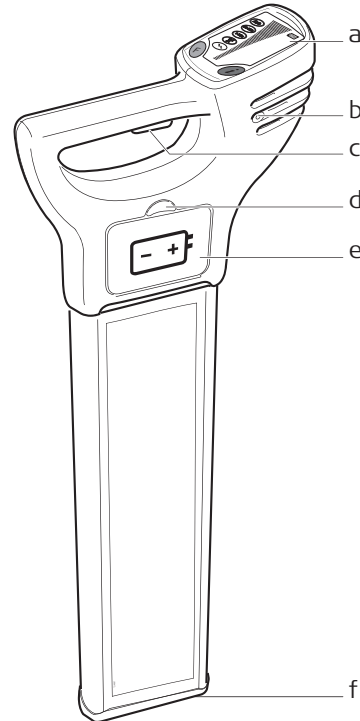

- a) **Display Panel**
Contains the operational controls.
- b) **Speakers** (mounted internally left and right)
Active at power on and when a signal is detected.
- c) **On/Off Trigger**
Press and hold the trigger to activate the Locator.
Release the trigger to deactivate.
- d) **Battery Hatch Release**
Pressing the yellow release button unlocks the battery hatch allowing access to the battery compartment.
- e) **Battery Compartment**
6 x LR6 (AA) alkaline batteries are used. Replace all batteries when indicated.
- f) **Case Foot**



The case foot can be replaced if it is worn. Contact your agency or Cable Detection authorised service workshop.

Display panel overview

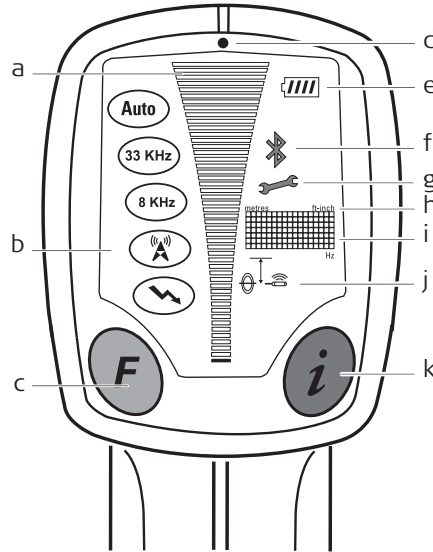

- a) **Signal Strength Indicator**
Indicates the response of the Locator to a signal (service).
- b) **Mode Indicators**
Displays the selected mode: Power, Radio, 8 kHz, 33 kHz, Auto (as shown, from bottom to top).
- c) **Function Button**
Selects operating mode.
- d) **Light Sensor**
Automatically switches the displays backlight on or off to suit light conditions.
- e) **Battery Indicator**
Indicates the battery condition. Segment illumination decreases as battery condition declines. Replace the batteries when the battery indicator is empty.
- f) **Bluetooth** (optional extra)
Indicates the Locator is paired to another device.
- g) **Wrench**
Indicates the Locator requires periodic service or unit is faulty.
- h) **Measurement Unit** (Depth indication with i550)
Indicates depth indication is in metric or feet and inches.
- i) **Display Readout**
Alpha numeric matrix indicates system set up and depth indication.
- j) **Depth Mode Indicators**
Indicates a depth reading to a service or a Sonde (i550 only). Service icon used to indicate Hazard zone on i500 and i550.
- k) **i Button**
Used to access the user settings and to provide a depth readout for the i550.

2.3

Locator Setup and Information

Locator settings

The i-Series Locators offer a range of settings which the operator can adjust to their own preference. It also displays additional service and contact information as detailed.

Setting	Description
EST	Performs a function check on the locators hardware and software, displaying PAS if the Locator is within predefined tolerance or ERR if the locator it is not.
H.Z	Switches hazard zone on or off.
VOL	Adjust volume level (0 - 10).
HLD	Adjust peak hold duration (0 - 5 seconds).
SSI	Displays a numeric signal strength indicator.
CST	Adjusts display's contrast (0 - 15).
M/I	Displays unit of measurement.
CAL	Displays the next service date DD/MM/YY.
CON	Displays supplier/company name.
TEL	Displays supplier/company telephone number.
I.D	Displays the operator's name.
PWR	Displays the power mode regional setting. Refer to "Appendix B World Frequency Zones" for more information.
SR#	Displays unit serial number.
VER	Displays software version

Accessing and adjusting the settings

1. Switch the Locator on.
2. Ensure the Locator is in Power mode.
If required, press Function Button to select mode.
3. Depress i Button for 2 seconds. The user settings will be displayed in the display readout.
4. Press Function Button to toggle through to desired setting.
5. Press i Button to select the setting.
6. Press Function Button to activate/adjust.
7. Press i Button to store and exit.

Danger

The Locator may fail to detect electrical services in Power mode if an incorrect power setting is used.

Precautions:

Before use, verify the Locator is setup to be compatible with mains frequency supply in your country. Options are 50 or 60 Hz. Refer to "Appendix B World Frequency Zones" for more information.

Contact your agency or Cable Detection authorised service workshop if your unit is incorrectly configured for your region.

Changing the battery

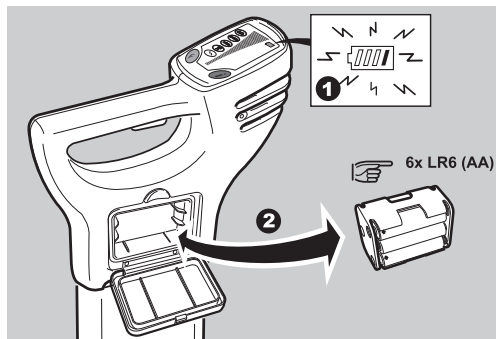

1. Replace the batteries when the battery status indicator is empty.
2. Press the yellow release button to unlock the Battery Hatch. Remove the battery holder from the Locator.
3. Replace all batteries with six new, LR6 (AA) batteries.

 Alkaline batteries should be used.

2.4



Hazard Zone

Description

Provides an additional warning to the close proximity of buried services and functions in the following modes:

- Power
- 8 kHz
- 33 kHz
- Auto mode (Power mode only)

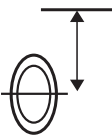
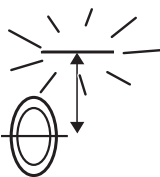
Hazard zone status indicators

Status indicator	Description
	Hazard zone is switched on.
	Hazard zone on and is alarming.
	Hazard zone is switched off.

 **Caution**

The absence of a positive indication does not guarantee the non-existence of a service. Services without a detectable signal may be present.

The Locators can only locate non-metallic services such as plastic pipes, typically used by the water and gas utilities, with the use of appropriate accessories.

Precautions:

Always excavate with care.

2.5

How to Locate a Service

Start up test

The following test sequence will take place every time the Locator is activated.

On test	Test pattern	Info on label
Audio Output	On throughout test sequence	
Signal Strength indicator	Scrolls through in sequence once	
Mode indicators	Briefly illuminated	
Battery indicator	On throughout	
Bluetooth and wrench	Briefly illuminated	
Measurement unit, display readout, depth mode indicator	Briefly illuminated	

The unit will then go into Power mode maximum sensitivity.

Locating process

The locating process is split into three steps:

- Sweep Search
- Pinpointing the service
- Direction of the service

Sweep Search

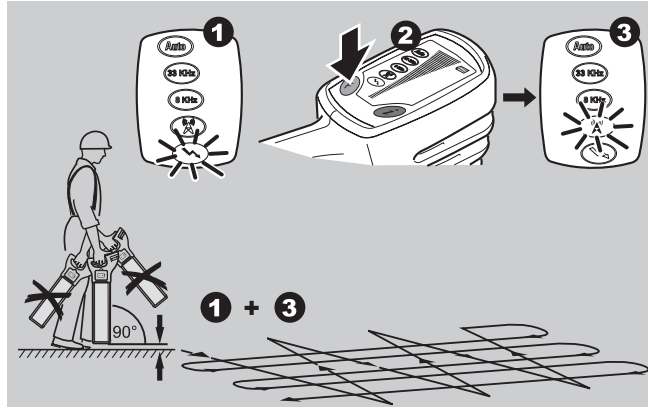

☞ The unit will automatically select Power mode and maximum sensitivity.

☞ Auto mode combines the benefit of simultaneous detection in Power and Radio modes and helps to confirm the presence of services upon initial site occupation. Improved definition of the service will be provided by single mode operation.

1. Define the area to be excavated.
2. In Power mode cross the site from left to right keeping the Locator upright, taking care not to swing the unit. Turn through 90 degrees and repeat.
☞ Ensure that the Locator is held in an upright position and close to the ground.
3. Continue the sweep until either a signal is located or you are satisfied that the area has been adequately tested.
☞ In the presence of a service emitting a traceable signal a tone will be emitted and the signal strength indicator will rise and fall as you pass over it.
4. Repeat the Sweep Search process in Radio mode.
☞ The Sweep Search must be conducted in Power and Radio modes as a minimum, as not all services (including some electrical ones) emit a power signal. These services may be found using Radio mode or active modes.

 Hazard zone can be operated in Power, 8 kHz, 33 kHz and Auto modes and provides an additional alarm to the presence of buried services which may be within close proximity.

Pinpointing the service

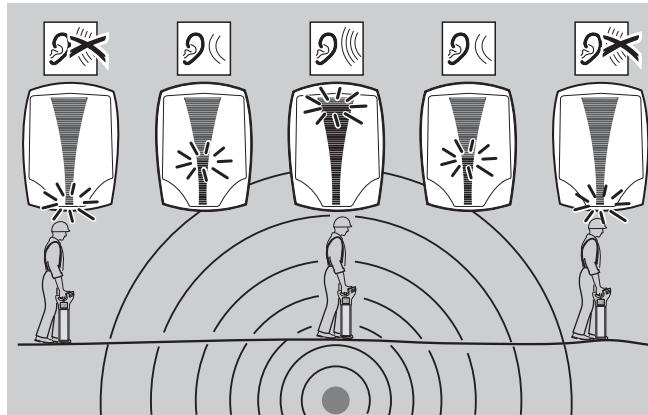

Retrace your steps to the area where the highest signal reading (peak response) was obtained. The service is directly below the Locator when the signal strength indicator is at its maximum. The audio output will automatically adjust to facilitate pinpointing over the service, and automatically reset when the signal strength indicator drops to its minimum position.



- Always use chalk or paint to mark services, **never** pegs.
- The signal strength indicator does not indicate the size, depth or type of a service.

Peak hold

When activated peak hold will show the highest peak reading obtained during the pinpoint process. The displayed reading can be adjusted between 0 to 5 seconds.

Detecting direction of the service

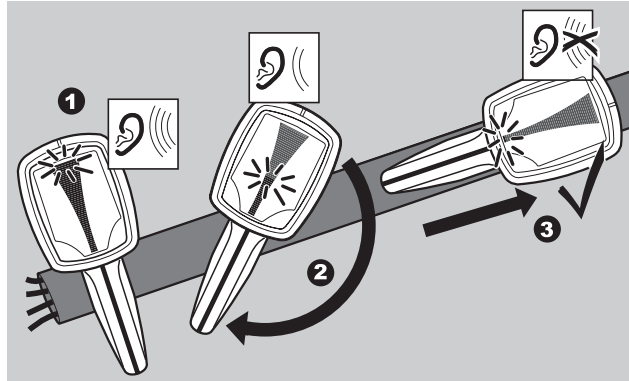

1. Position the Locator directly over the service.
2. Rotate the Locator on its axis.
3. The blade of the Locator will be in line with the service when the signal strength indicator is at its minimum.

Depth Indication (i550 only)

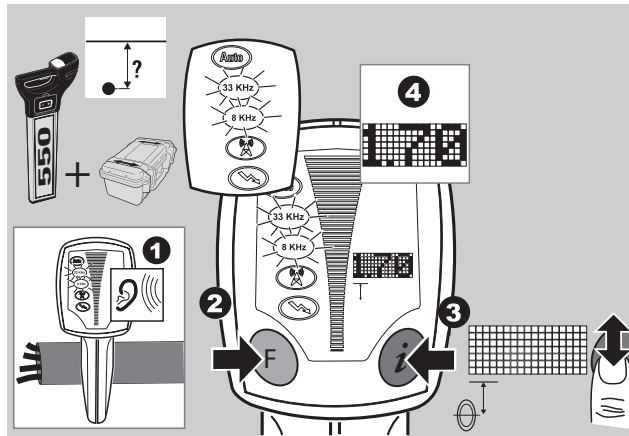

1. Apply a signal to the service. Refer to "3 How to Use the Transmitter" for more information.
2. Select either 33 kHz or 8 kHz modes to suit the the Transmitter's output. Position the Locator directly over, and at 90 degrees to the direction of the service.
3. Press and release the i Button.
4. The display readout will indicate the depth of the service and the Line mode icon will be displayed.



- Activating Sonde depth will provide an inaccurate readout.
- Always use chalk or paint to mark services, **never** pegs or other material which are driven into the ground.
- Additional services may be within the excavation zone, as well as the service you are taking a depth reading from.
- The reading will be more accurate when taken over a straight run, where the service does not bend, or have a service crossing it or coming off it.

Depth shown and actual depth:

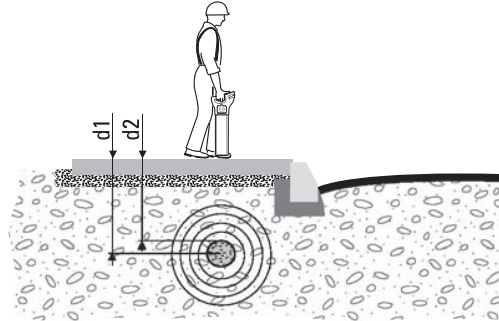

- d1 Depth shown on the EZiCAT = depth to the centre of the line.
d2 Actual depth of the service.

Note the difference between d1 and d2 !

Warning

The depth reading might not reflect the real depth if your Locator picks up the signal induced into the service by the Transmitter. This signal is radiated from the centre of the service.
This is even more important when the signal is produced by a Sonde, lying in a large diameter conduit!

Precautions:

Always compensate depth reading for service size.

Measuring Sonde depth (i550 only)

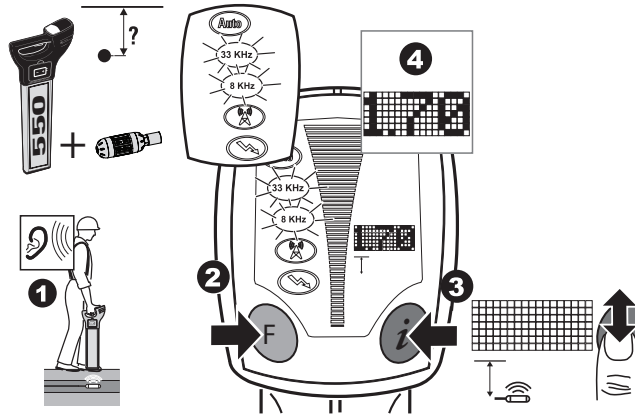

1. Switch on the sonde and set to the required frequency. Refer to "7 How to Use the Sonde" for more information.
2. Select either 33 kHz or 8 kHz mode to suit the Sonde's output.
Position the Locator directly over, and in line with the Sonde. Refer to "7 How to Use the Sonde" for more information.
3. Press and hold down the **i** Button for 2 seconds until the dashed lines have scrolled through once.
4. The display readout will indicate the depth of the Sonde and the Sonde mode icon will be displayed.



- Activating line depth will provide an inaccurate readout.
- Always use chalk or paint to mark services, **never** pegs or other material which are driven into the ground.
- Additional services may be within the excavation zone, as well as the service you are taking a depth reading from.

Depth shown and diameter:

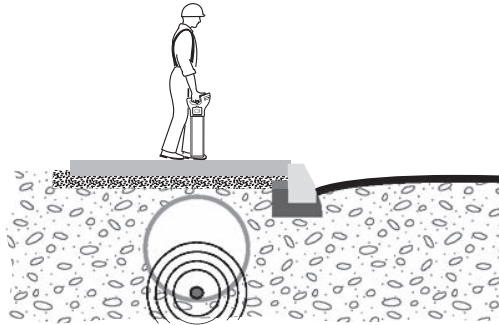

Take special care when the signal is produced by a sonde, lying in a large diameter conduit!

Warning





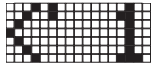
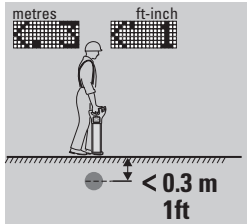

The depth reading may not indicate the real depth of the service, especially if the sonde is lying at the base of a large diameter duct.

Precautions:

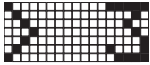
Always compensate depth reading for service size.

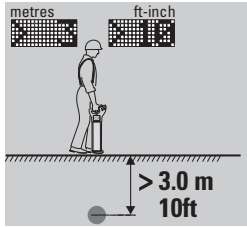
Depth code information

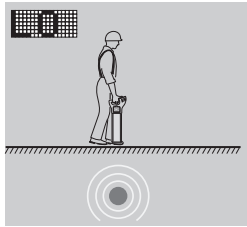
Information code	Description	Information on instrument label
 metres  ft-inch	The service is too shallow to register properly.	

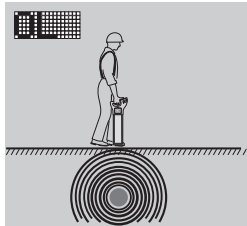
Information code	Description	Information on instrument label
 metres  ft-inch	The service is too deep.	
	The signal received by the Locator is too small to register properly.	
	The signal received by the Locator is too large to register properly.	

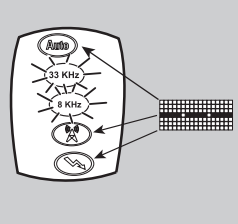
Information code	Description	Information on instrument label
 A 10x10 grid with the second row filled with black squares, representing the information code for this error.	Depth function not available. The Locator is set to the wrong mode for a depth reading to be taken.	 A diagram of the instrument's control panel. It features a 'Auto' button at the top, followed by a '33 KHZ' label and a '6 KHZ' label. Below these are two circular buttons with symbols. A grid of black squares is shown to the right, with arrows pointing from it to the '33 KHZ' and '6 KHZ' labels, indicating that the instrument is set to the wrong mode.

2.6

Wireless Data Communication, where applicable

Bluetooth

Bluetooth connectivity is an optional extra available on the i500 and i550 Locators. Data can be wirelessly transferred from the Locator to a suitable data logging device, enabling the operator to capture information about the Locator's status and the service depth. When the Locator is paired to a suitable logger, the Bluetooth symbol will flash, and the unit will transmit data periodically.

Important information for pairing:

- The Locator must be switched on throughout the process
 - Follow the instructions on the logger for pairing. Refer to the manufacturer's instructions.
-

Pairing information

Device Name: 'Model Number' - 'Serial Number'
for example: 550-000001

Pass key: 12345



- The Bluetooth symbol will flash continually when the devices have successfully paired.
 - When a depth reading has been taken, the Locator will display **LOG**. To transfer the information to the data logger press the i Button whilst **LOG** is displayed.
 - Whilst the Locator is calculating depth the data output stops.
 - If there is no wireless communication then the LOG function will not be displayed and the unit will function as a Locator.
 - The Locator will output ASCII text.
Refer to "ASCII text description" for more information.
-

ASCII text description

ASCII output pattern:

DVxxxSNxxxxSVxxTMxxxxDTdd/mm/yyCMxxCMxSTxxBTxxMDxxSSxxUMxxDPXX

Data output	Range	Example value	Description
DV	000 to 999	550	Model identifier
SN	000000 to 999999	123456	Serial number
SV	0.00 to 9.99	3.01	Software version
TM	00:00 to 23:59	08:30	Time: hh:mm (default = 00:00; no RTC fitted)
DT	00/00/00 to 31/12/99	01/12/10	Date: dd/mm/yy (default = 00/00/00; no RTC fitted)
CM	00 to 15	12	Number of months until next calibration (00 to 15)
ST	0 or 1	0	Self test: 0 = Pass, 1 = Fail
BT	0 to 9	7	Battery level: 0 = Empty, 9 = Good
MD	0 to 4	3	Mode: 0 = Power, 1 = Radio, 2 = 8 kHz, 3 = 33 kHz, 4 = Auto
SS	01 to 48	16	Signal strength: 01 to 48
UM	M or I	M	Units of measurements: M or I (Metres or Imperial)
DP	0.30 to 3.00 or ---	125	Depth value displayed depends on value for UM.

3

How to Use the Transmitter

3.1

General information

Tracing signal

The Transmitter applies an electrical current signal onto a buried metallic service, which enables the service to be traced and identified by the Locator operating in the same mode.

Operating mode

There are three operating modes for onsite flexibility:

- 8 kHz for congested site operation
 - 33 kHz for general usage
 - Combined 8 kHz and 33 kHz available in Connection mode, enabling rapid selection and convenience on congested sites. The Locator can be used in either mode.
-

Description

Active tracing is a term frequently used when a Transmitter is used to apply a signal to a service enabling it to be traced. The use of a Transmitter will greatly improve the detection of services especially ones which may not have a signal on them.

The signal from the Transmitter can be applied to services in two ways:

- **Induction mode** (8 kHz or 33 kHz):
Induction is a quick and simple way to apply a signal to a service without the need to make any physical connection to it. The Transmitter uses an internal aerial to transmit the signal, therefore it should be noted that the signal will apply itself to additional services within close proximity to the Transmitter.
 - **Connection mode** (8 kHz or 33 kHz or combined 8 kHz and 33 kHz):
This is the most efficient way of applying a signal to a service, and should be used whenever possible. The Transmitter's cable set or any of the available accessories are connected to the service which is to be traced or identified.
-



- 8 kHz is less likely to apply itself to additional services making tracing in areas of multiple services easier.
 - 33 kHz is suitable for general site use.
 - Combined 8 and 33 kHz (Connection mode only) is useful in congested areas when either 8 or 33 kHz may provide a better result. The best results can be simply achieved by switching modes on the Locator.
-

3.2

Transmitter Overview

Transmitter main parts

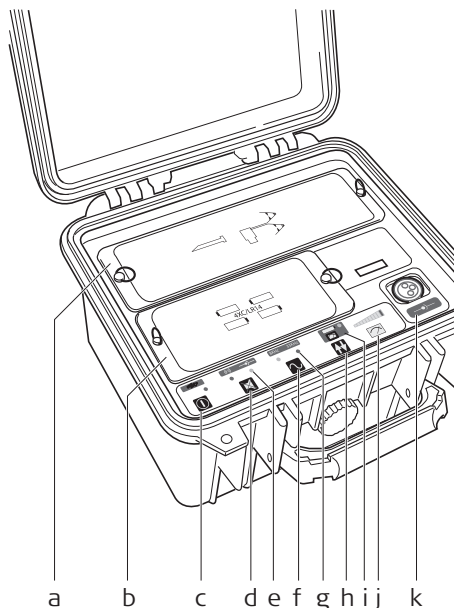

- a) **Accessory Cover**
- b) **Battery Cover**
- c) **Power Control**
Switches the unit on or off.
- d) **Mute Control**
Used to silence the Transmitter.
- e) **Mode Display**
Indicates which mode is selected: Induction or Connection.
- f) **Frequency Control Button**
Used to select 8 kHz or 33 kHz output.
- g) **Frequency Display**
Indicates which frequency is selected 8 kHz or 33 kHz.
- h) **Output Level Control**
Used to vary the signal output of the Transmitter.
- i) **Battery Indicator**
Flashes when the batteries need to be replaced. Replace all batteries when indicated.
- j) **Level Meter Display**
Indicates the signal output level, and the condition of the batteries on initial start up.
- k) **Connection Socket**
Used to connect accessories directly to metallic services. (Standard: crocodile clip cable set.)

Changing the battery

The battery indicator flashes when approximately 20% of battery life remains. The rate of flashing increases as the battery life declines.

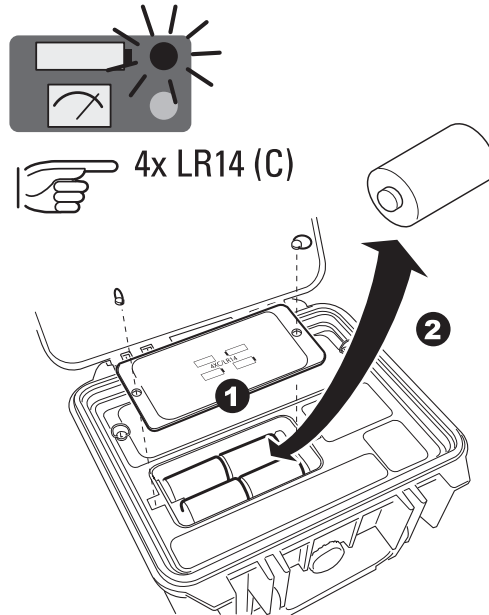

1. Loosen the two screws of the battery cover and remove them together with the cover.
2. Replace all batteries with four new LR14 (C) batteries.

☞ Alkaline batteries should be used.

3.3

How to Locate a Service Using the Transmitter

Start up test

The following test sequence will take place every time the Transmitter is activated.

On test	Test pattern
	
Audio output	On throughout test sequence.
LEDs	LEDs are all lit throughout the test sequence.
Battery low indication	Battery level is shown throughout the test sequence, flashes if batteries are low.
Default mode selection	33 kHz and maximum output level are automatically selected. Induction mode output is selected unless the transmitter's cable set or accessories are connected.

Using the Transmitter in Induction mode

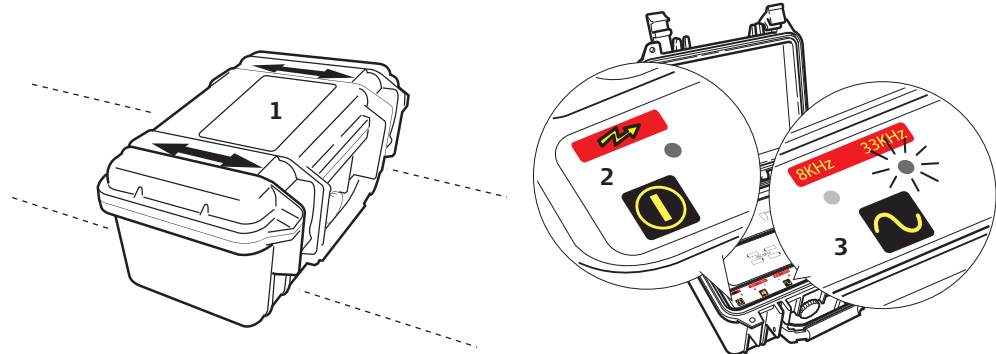

1. Place the Transmitter over the service with the arrows on top of the case lid running in line with the suspected direction of the service.
2. Switch the Transmitter on and observe the battery level. Change batteries when indicated.
3. Select 8 kHz or 33 kHz mode, adjust output if required.
The tracing signal is induced directly onto the service from the internal aerial.
4. Trace the path of the service using the Locator set to the same frequency. Refer to "2 How to Use the Locator" for more information.



- Work at least 10 m / 33 ft away from the Transmitter to avoid airborne signals. Reposition the Transmitter if required.
- Coupling efficiency is best at 33 kHz.
- The signal will couple to adjacent services dependent on depth and direction.
- Reducing the signal output can help to increase the battery life and the Transmitter is less likely to apply a signal to an adjacent service.

Using the Transmitter in Connection mode

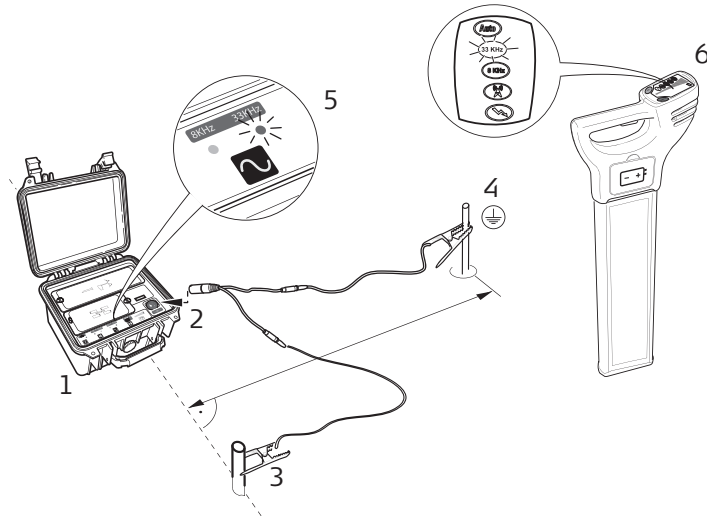

1. Switch the Transmitter on and observe the battery level. Change batteries when indicated.
2. Plug the Transmitter's cable set into the connection socket, the Transmitter will go into Connection mode as indicated on the mode display.
3. Connect the red cable to the service, a magnet is provided to assist on large services.
4. Connect the black cable to earth pin, ensuring that no services are below push the earth pin into the ground.
A good level of tracing signal is indicated when the audible output changes from pulsed to continuous, and the signal level output goes to maximum.
5. Select 8 kHz, 33 kHz or combined 8 and 33 kHz mode. Adjust output if required.
6. Trace the signal using the Locator set to the same operating mode. Refer to "2 How to Use the Locator" for more information.

 **Danger**

Connecting the cable set to a live service can result in receiving an electric shock.

Precautions:

The connection cable set should never be connected directly to a live service.



- Ensure there are no services below the ground when using the earth pin. Use the Locator in advance.
 - The black cable can be connected to other metallic structures which go into the ground.
 - In dry conditions it may be necessary to add water around the earth point to get a good connection.
 - Examine connection points and remove contamination if a continuous audible output is not achieved.
 - An extension cable is available to extend the red or black cable sets.
-

4

4.1

Description

How to Use the Conductive Rod

General Information

The Conductive Rod is a service tracer enabling small diameter non-conductive pipes or ducts to be traced. It can be used in Line mode or Sonde mode.

4.2

Conductive Rod Overview

Conductive Rod main parts

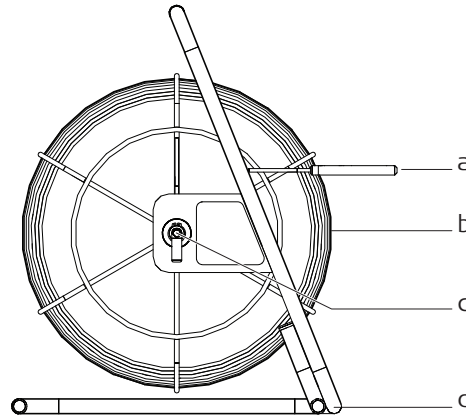

- a) **End of Coil: Sonde mode**
Used to accurately pinpoint the end point of the rod.
 - b) **Rod: Line mode**
Flexible, Glass Fibre sheathed, which incorporates copper wires to conduct the signal.
 - c) **Signal connection socket**
Used to connect to the Transmitter.
 - d) **Frame**
Houses the flexible rod. Can be used in both vertical (shown) and horizontal orientation.
-

4.3

How to Locate a Service Using the Conductive Rod

Using the Conductive Rod in Line mode

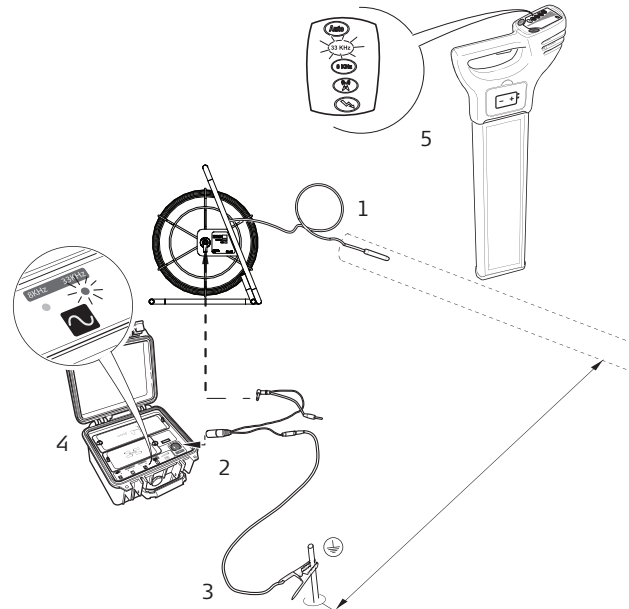

1. Insert the rod into the pipe, duct, conduit or drain until the desired length is in place.
2. Connect the Transmitter's cable set to the Transmitter socket and the rod socket in the middle of the frame.
3. Separate the black cable and connect the supplied crocodile clip cable, connect this to a suitable earth point.
4. Switch the Transmitter on and select 8 kHz or 33 kHz. A good signal is indicated when the audible output from the Transmitter is constant. The signal applies itself evenly along the length of the Conductive Rod.
5. Trace the length of the rod using the Locator set to the same frequency.



- Ensure there are no services below the ground when using the earth pin. Use the Locator in advance.
- At least half the Conductive Rod needs to be uncoiled when in use.

Using the Conductive Rod in Sonde mode

1. Insert the rod into the pipe, duct, conduit or drain until the desired length is in place.
2. Connect the cable set to the Transmitter socket and the rod socket in the middle of the frame. The black cable must be connected directly between Transmitter and Conductive Rod.
3. Switch the Transmitter on and select 8 kHz or 33 kHz.
A good signal output is indicated when the audible output from the Transmitter is constant. The majority of the signal is concentrated towards the Sonde.
4. Trace the length of the rod using the Locator set to the same frequency.



At least half the Conductive Rod needs to be uncoiled when in use.

5 How to Use the Signal Clamp

5.1 General Information

Description

The Signal Clamp provides a safe technique of applying a signal to services such as telecom cables, etc. It is connected to the Transmitter and then clipped around the service. Supply is not interrupted by the applied signal.

5.2 Signal Clamp Overview

Signal Clamp main parts

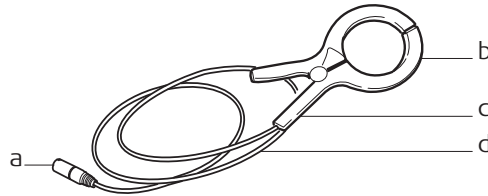

- a) Transmitter plug connector
 - b) Jaws
 - c) Handle
 - d) Cable
-

5.3

How to Locate a Service Using the Signal Clamp

Using the Signal Clamp

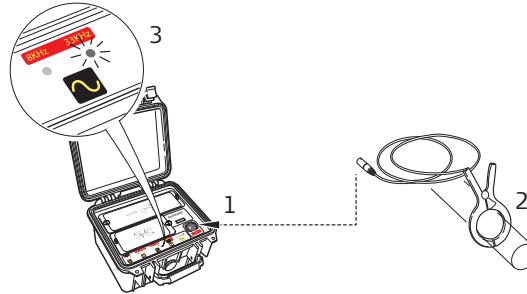

1. Connect the Signal Clamp to the Transmitter.
2. Open the jaws of the Signal Clamp and place around the service to be traced.
3. Switch the Transmitter on and select 33 kHz.
A good signal output is indicated when the audible output from the Transmitter is constant.
4. Trace the length of the service using the Locator set to the same frequency.



- Ensure the clamp jaws are fully engaged.
- Works best in 33 kHz mode.

Danger

A hazardous signal may be present on the connection plug of the Signal Clamp when clipped over a live service.

Precautions:

The clamp should be connected to the Transmitter before clamping around a live service.



A hazardous signal may be present on the service causing personal harm.

Precautions:

Do not use on electrical services which have impaired, or no insulation. If in doubt do not use.

6 How to Use the Property Connection Set

6.1 General Information

Description

The Property Connection Set provides a safe technique of applying a traceable signal to live electricity cables. It is connected to the service via a mains plug outlet and provides a traceable signal. Supply is not interrupted by the applied signal and the risk of serious injury is greatly reduced.

6.2 Property Connection Set Overview

Property Connection Set main parts

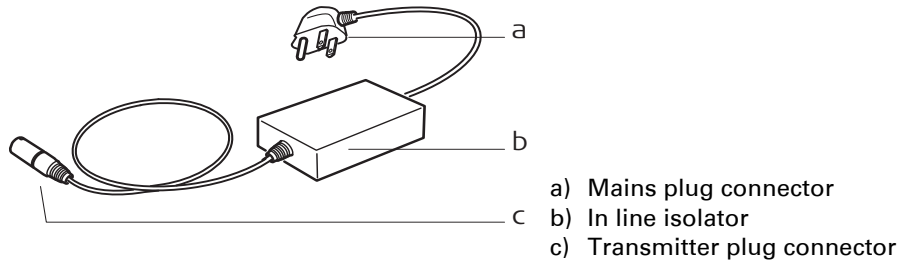

6.3

How to Locate a Service Using the Property Connection Set

Using the Property Connection Set

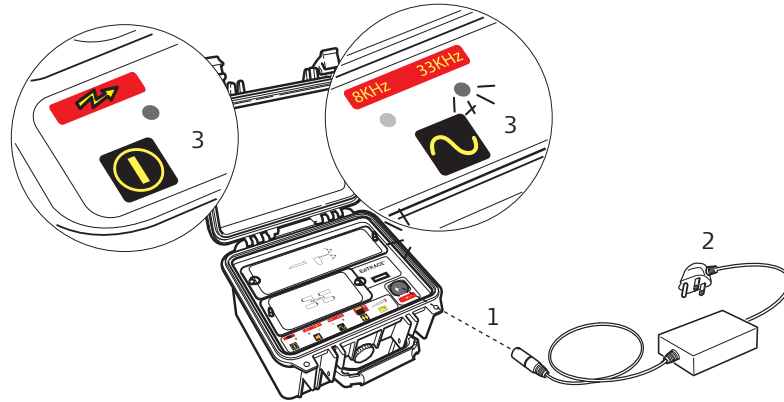

1. Connect the Property Connection Set to the Transmitter.
2. Connect the Property Connection Set to a live mains outlet. Ensure the switch on the mains is on.
3. Switch the Transmitter on and select 33 kHz.
A good signal output is indicated when the audible output from the Transmitter is constant.
4. Trace the length of the service using the Locator set to the same frequency.



- The mains supply must be live and switched on for correct operation.
- Works best with 33 kHz.

 **Danger**

A hazardous signal may be present on the connection plug of the Property Connection Set when connected to the mains supply.

Precautions:

The Property Connection Set should be connected to the Transmitter before connecting to the mains supply.

 **Danger**

A hazardous signal may be present on the service or mains outlet causing personal harm.

Precautions:

Do not use on electrical services which have impaired, or no insulation. If in doubt do not use.

7 How to Use the Sonde

7.1 General Information

Description

The Sonde is a dual frequency signal transmitter used to trace drains, sewers and other non conductive services. It can be attached to a range of equipment including drain rods, boring tools and inspection cameras. It is powered by a 1.5 V LR6 (AA) battery, so unlike other accessories this does not require a connection to the transmitter.

The signal pattern transmitted from the Sonde is different to that which is radiated from a service; transmitting a peak signal over its main body, with a ghost signal at the front and back. This requires the Sonde to be traced with its own unique method.

The i-Series Locators feature a numeric signal strength indicator (user setting **SSI** set to ON) which will greatly improve the locating process.



The numeric signal strength indicator is shown in the display readout on the Locator.

7.2 Sonde Overview

Sonde main parts

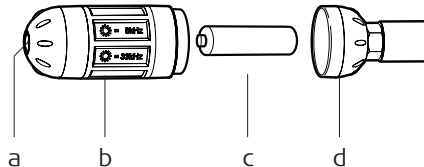

- a) LED
- b) Sonde body
- c) LR6 (AA) battery
- d) End cap and M10 connection point



The thread on the Sonde is a male M10, and comes with adaptors to both British and European drain rods.

Changing the frequency output

Changing to 33 kHz mode:

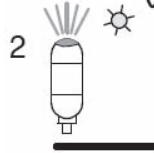
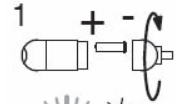

1. Unscrew and remove end cap.
Insert battery, positive end first.
Refit end cap securely.
2. Hold Sonde upright.
Confirm green LED is continuous.
3. Wait approximately 10 seconds for the green LED to start flashing.
4. With the green LED flashing, the Sonde is ready for use at 33 kHz.

Changing to 8 kHz mode:

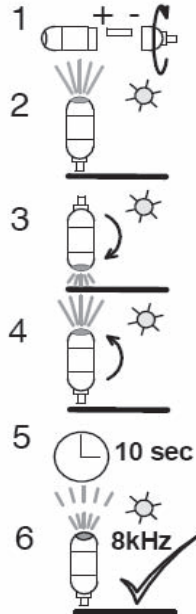

1. Unscrew and remove end cap.
Insert battery, positive end first.
Refit end cap securely.
2. Hold Sonde upright.
Confirm green light is continuous.
3. Rotate Sonde so the LED points down and wait approximately 1 second.
4. Rotate Sonde upright.
Confirm the amber coloured LED is continuous.
If LED remains green repeat from step 1.
5. Wait approximately 10 seconds for the amber LED to start flashing.
6. With the amber LED flashing, the Sonde is ready for use at 8 kHz.



Once the function of the Sonde has been checked with a Locator set to the same operating mode it can be attached to drain rods or other means of guiding it into the service being traced.

7.3

How to Locate a Service Using the Sonde

Locating the Sonde

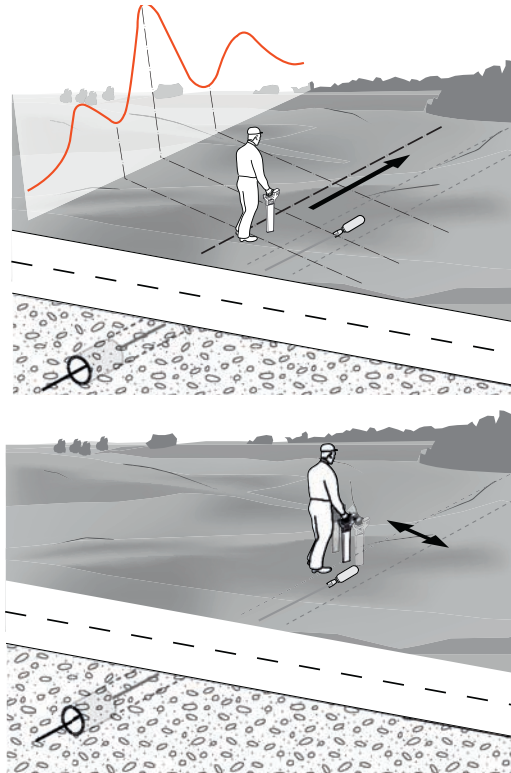

1. Walk in line with the suspected direction of travel observing the display. The signal strength indicator will rise and fall as you pass over the ghost signal at the back of the Sonde, the peak signal directly over the Sonde and the ghost signal at the front. The numeric signal strength indicator will display its highest value when detecting the peak signal.
2. Retrace your steps and position the locator directly over the peak signal. Move the locator left and right until the highest numeric reading is obtained. This reading will indicate the Sonde's precise location.

3. Depth indication (i550 only)

Depth indication can be used with a suitable depth locator. The locator must be positioned directly over the Sonde and in line with it (rotate the locator on its axis to find the highest reading). Press and hold the i Button for 2 seconds. The depth of the Sonde will be displayed in the depth readout window and the Sonde mode icon will be visible beneath the display.



- For ease and convenience mark the ground every 3 to 4 metres.
- For ease of use practice the process above ground

Tracing a "walk through" sewer

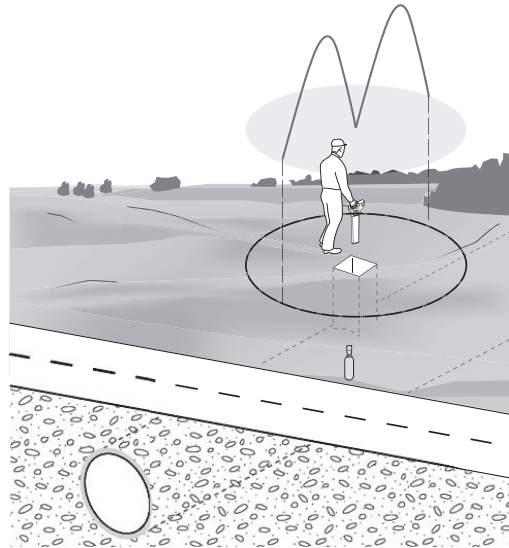

If a "walk through" sewer is being traced, another method is to place the Sonde vertically, for example to pinpoint a buried manhole. The Locator will pick up a pool of signal with a null point at the centre. This is an accurate method, but it is essential to ensure the Sonde is vertical.

8

Care and Transport

8.1

Transport

Transport in the field

When transporting the equipment in the field, always make sure that you carry the product in its original transport container.

Transport in a road vehicle

Never carry the product loose in a road vehicle, as it can be affected by shock and vibration. Always carry the product in its transport container and secure it.

Shipping

When transporting the product by rail, air or sea, always use the complete original Cable Detection packaging, transport container and cardboard box, or its equivalent, to protect against shock and vibration.

Shipping, transport of batteries

When transporting or shipping batteries, the person in charge of the product must ensure that the applicable national and international rules and regulations are observed. Before transportation or shipping, contact your local passenger or freight transport company.

8.2

Storage

Product

Respect the temperature limits when storing the equipment, particularly in summer if the equipment is inside a vehicle. Refer to "10 Technical Data" for information about temperature limits.

If the equipment is to be stored for a long time, remove the alkaline batteries from the product in order to avoid the danger of leakage.

8.3**Cleaning and Drying**

Damp products

Dry the product, the transport container, the foam inserts and the accessories at a temperature not greater than 40°C / 104°F and clean them. Do not repack until everything is completely dry.

Cables and plugs

Keep plugs clean and dry. Blow away any dirt lodged in the plugs of the connecting cables.

9

Safety Directions

9.1

General Introduction

Description

The following directions should enable the person responsible for the product, and the person who actually uses the equipment, to anticipate and avoid operational hazards.

The person responsible for the product must ensure that all users understand these directions and adhere to them.

9.2

Intended Use

Permitted use

The products are intended to be used for the following applications:

- Detection and localization of underground services: cables and metallic pipes.
 - Locator i500, i550: Detection and localization of a Sonde Transmitter.
 - Locator i500, i550: Detection and localization of Conductive Rod accessory.
 - Locator i550: Estimation of the depth of an underground service, a Sonde or Conductive Rod.
 - Locator i500, i550 with Bluetooth: Data communication with external appliances.
-

Adverse use

- Use of the product without instruction.
- Use outside of the intended limits.
- Disabling safety systems.
- Removal of hazard notices.
- Opening the product using tools, for example screwdriver, unless this is specifically permitted for certain functions.
- Modification or conversion of the product.
- Use after misappropriation.

- Use of products with obviously recognizable damages or defects.
- Use with accessories from other manufacturers without the prior explicit approval of Cable Detection.
- Inadequate safeguards at the surveying site, for example when measuring on roads.

 **Warning**

Adverse use can lead to injury, malfunction and damage. It is the task of the person responsible for the equipment to inform the user about hazards and how to counteract them. The product is not to be operated until the user has been instructed on how to work with it.

9.3**Limits of Use****Environment**

Suitable for use in an atmosphere appropriate for permanent human habitation: not suitable for use in aggressive or explosive environments.

 **Danger**

Local safety authorities and safety experts must be contacted before working in hazardous areas, or in close proximity to electrical installations or similar situations by the person in charge of the product.

9.4**Responsibilities****Manufacturer of the product**

Cable Detection Ltd, Staffordshire, UK, hereinafter referred to as Cable Detection, is responsible for supplying the product, including the user manual and original accessories, in a completely safe condition.

Manufacturers of non Cable Detection accessories

The manufacturers of non Cable Detection accessories for the product are responsible for developing, implementing and communicating safety concepts for their products, and are also responsible for the effectiveness of those safety concepts in combination with the Cable Detection product.

Person in charge of the product

The person in charge of the product has the following duties:

- To understand the safety instructions on the product and the instructions in the user manual.
- To be familiar with local regulations relating to safety and accident prevention.
- To inform Cable Detection immediately if the product and the application becomes unsafe.

Warning

The person responsible for the product must ensure that it is used in accordance with the instructions. This person is also accountable for the training and the deployment of personnel who use the product and for the safety of the equipment in use.

9.5

Hazards of Use

Warning

The absence of instruction, or the inadequate imparting of instruction, can lead to incorrect or adverse use, and can give rise to accidents with far-reaching human, material, financial and environmental consequences.

Precautions:





All users must follow the safety directions given by the manufacturer and the directions of the person responsible for the product.

Caution

Watch out for erroneous measurement results if the product has been dropped or has been misused, modified, stored for long periods or transported.

Precautions:

Periodically carry out test measurements and perform tests indicated in the user manual, particularly after the product has been subjected to abnormal use and before and after important measurements.

-
-  **Danger**
- Because of the risk of electrocution, it is very dangerous to use the product in the vicinity of electrical installations such as power cables or electrical railways.
- Precautions:**
Keep at a safe distance from electrical installations. If it is essential to work in this environment, first contact the safety authorities responsible for the electrical installations and follow their instructions.
-
-  **Warning**
- During dynamic applications, for example stakeout procedures there is a danger of accidents occurring if the user does not pay attention to the environmental conditions around, for example obstacles, excavations or traffic.
- Precautions:**
The person responsible for the product must make all users fully aware of the existing dangers.
-
-  **Caution**
- The absence of a positive indication does not guarantee the non-existence of a service. Services without a detectable signal may be present.
- The Locators can only locate non-metallic services such as plastic pipes, typically used by the water and gas utilities, with the use of appropriate accessories.
- Precautions:**
Always excavate with care.
-
-  **Warning**
- Only with a Locator with depth:**
The depth reading might not reflect the real depth if your Locator picks up the signal induced into the service by the Transmitter. This signal is radiated from the centre of the service.
- This is even more important when the signal is produced by a Sonde, lying in a large diameter conduit!
- Precautions:**
Always compensate depth reading for service size.
-

 **Danger**

The Locator may fail to detect electrical services in Power mode if an incorrect power setting is used.

Precautions:

Before use, verify the Locator is setup to be compatible with mains frequency supply in your country. Options are 50 or 60 Hz. Refer to "Appendix B World Frequency Zones" for more information.

Contact your agency or Cable Detection authorised service workshop if your unit is incorrectly configured for your region.

 **Danger**

Only with Transmitter:

A hazardous signal may be present on the connection plug of the Signal Clamp when clipped over a live service.

Precautions:

The clamp should be connected to the Transmitter before clamping around a live service.

 **Danger**

Connecting the Transmitter's cable set to a live service can result in receiving an electric shock.

Precautions:

The Transmitter's cable set should never be connected directly to an electrical live service.

 **Danger**

When using a signal clamp, a hazardous signal may be present on the service causing personal harm.

Precautions:

Do not use on electrical services which have impaired, or no insulation. If in doubt do not use.

 **Danger**

When using a Property Connection Set a hazardous signal may be present on the service or mains outlet causing personal harm.

Precautions:

Do not use on electrical services which have impaired, or no insulation. If in doubt do not use.

 **Warning**

Inadequate securing of the surveying site can lead to dangerous situations, for example in traffic, on building sites, and at industrial installations.

Precautions:

Always ensure that the survey site is adequately secured. Adhere to the regulations governing safety and accident prevention and road traffic.

 **Warning**

If the product is improperly disposed of, the following can happen:

- If polymer parts are burnt, poisonous gases are produced which may impair health.
- If batteries are damaged or are heated strongly, they can explode and cause poisoning, burning, corrosion or environmental contamination.
- By disposing of the product irresponsibly you may enable unauthorised persons to use it in contravention of the regulations, exposing themselves and third parties to the risk of severe injury and rendering the environment liable to contamination.
- Improper disposal of silicone oil may cause environmental contamination.

Precautions:

The product must not be disposed with household waste. Dispose of the product appropriately in accordance with the national regulations in force in your country. Always prevent access to the product by unauthorised personnel.

Product specific treatment and waste management information can be downloaded from the Cable Detection home page at <http://www.cabledetection.co.uk/treatment> or received from your Cable Detection dealer.

 **Caution**

During the transport, shipping or disposal of batteries it is possible for inappropriate mechanical influences to constitute a fire hazard.

Precautions:

Before shipping the product or disposing of it, discharge the batteries by running the product until they are flat.

When transporting or shipping batteries, the person in charge of the product must ensure that the applicable national and international rules and regulations are observed. Before transportation or shipping contact your local passenger or freight transport company.

 **Warning**

High mechanical stress, high ambient temperatures or immersion into fluids can cause leakage, fire or explosions of the batteries.

Precautions:

Protect the batteries from mechanical influences and high ambient temperatures. Do not drop or immerse batteries into fluids.

 **Warning**

If battery terminals come in contact with jewellery, keys, metallised paper or other metals, short circuited battery terminals can overheat and cause injury or fire, for example by storing or transporting in pockets.

Precautions:

Make sure that the battery terminals do not come into contact with metallic objects.

 **Warning**

Only Cable Detection authorised service workshops are entitled to repair these products.

9.6

Electromagnetic Compatibility EMC

Description

The term Electromagnetic Compatibility is taken to mean the capability of the product to function smoothly in an environment where electromagnetic radiation and electrostatic discharges are present, and without causing electromagnetic disturbances to other equipment.

 **Warning**

Electromagnetic radiation can cause disturbances in other equipment.

Although the product meets the strict regulations and standards which are in force in this respect, Cable Detection cannot completely exclude the possibility that other equipment may be disturbed.

 **Caution**

There is a risk that disturbances may be caused in other equipment if the product is used in conjunction with accessories from other manufacturers, for example field computers, personal computers, two-way radios, non-standard cables or external batteries.

Precautions:

Use only the equipment and accessories recommended by Cable Detection. When combined with the product, they meet the strict requirements stipulated by the guidelines and standards. When using computers and two-way radios, pay attention to the information about electromagnetic compatibility provided by the manufacturer.

 **Caution**

Disturbances caused by electromagnetic radiation can result in erroneous measurements. Although the product meets the strict regulations and standards which are in force in this respect, Cable Detection cannot completely exclude the possibility that the product may be disturbed by very intense electromagnetic radiation, for example, near radio Transmitters, two-way radios or diesel generators.

Precautions:

Check the plausibility of results obtained under these conditions.

 **Warning**

If the product is operated with connecting cables attached at only one of their two ends, for example external supply cables, interface cables, the permitted level of electromagnetic radiation may be exceeded and the correct functioning of other products may be impaired.

Precautions:

While the product is in use, connecting cables, for example product to external battery, product to computer, must be connected at both ends.

 **Warning****Only with Transmitter and Sonde:**

Electromagnetic fields can cause disturbances in other equipment, in installations, in medical devices, for example pacemakers or hearing aids and in aircraft. It can also affect humans and animals.

Precautions:

Although the product meets in combination with radio or digital cellular phone devices recommended by Cable Detection the strict regulations and standards which are in force in this respect, Cable Detection cannot completely exclude the possibility that other equipment may be disturbed or that humans or animals may be affected.

- Do not operate the product with radio or digital cellular phone devices in the vicinity of filling stations or chemical installations, or in other areas where an explosion hazard exists.
 - Do not operate the product with radio or digital cellular phone devices near to medical equipment.
 - Do not operate the product with radio or digital cellular phone devices in aircraft.
 - Do not operate the product with radio or digital cellular phone devices for long periods with it immediately next to your body.
-

9.7

FCC Statement, Applicable in U.S.

 **Warning**

This equipment has been tested and found to comply with the limits for a Class B digital device, pursuant to part 15 of the FCC rules.

These limits are designed to provide reasonable protection against harmful interference in a residential installation.

This equipment generates, uses and can radiate radio frequency energy and, if not installed and used in accordance with the instructions, may cause harmful interference to radio communications. However, there is no guarantee that interference will not occur in a particular installation.

If this equipment does cause harmful interference to radio or television reception, which can be determined by turning the equipment off and on, the user is encouraged to try to correct the interference by one or more of the following measures:

- Reorient or relocate the receiving antenna.
- Increase the separation between the equipment and the receiver.
- Connect the equipment into an outlet on a circuit different from that to which the receiver is connected.
- Consult the dealer or an experienced radio/TV technician for help.

 **Warning**

Changes or modifications not expressly approved by Cable Detection for compliance could void the user's authority to operate the equipment.

Labelling Locator



Labelling Transmitter

Power 6V Nom.
300mA Max.
Made in the UK



.....
.....
.....



This device complies with part 15 of the FCC Rules. Operation is subject to the following two conditions: (1) This device may not cause harmful interference, and (2) this device must accept any interference received, including interference that may cause undesired operation.

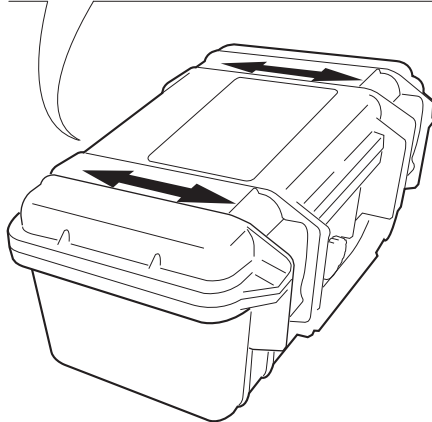

10

10.1

Technical Data

Locator i-Series Technical Data

Typical detection range

Mode	Distance along conductor
Power mode	length of conductor
Radio mode	length of conductor
Conductive Rod mode	length of unwound rod

Operating depth range

Mode	Range
Power mode	to 3 m / 10 ft
Radio mode	to 2 m / 7 ft
Transmitter mode	to 3 m / 10 ft

Typical depth accuracy

EZiCAT i500	EZiCAT i550
N/A	10% of depth in line or Sonde
N/A	0.3 to 3.0 m (1 to 10 ft) depth range

Operating frequencies

Mode	Frequency
Power mode	50 Hz or 60 Hz
Radio mode	15 kHz to 60 kHz
8 kHz mode	8.192 (8) kHz

Mode	Frequency
33 kHz mode	32.768 (33) kHz
Auto mode	Power mode and Radio mode

Display panel

- 48 segment bar graph
- 5 mode indicators
- Battery status indicator
- Line depth indicator
- Sonde depth indicator
- Bluetooth indicator
- Integrated backlight
- Annual service indicator
- 3 alpha numeric dot matrix displays 5x7

Keypad

2 membrane push buttons

Speakers

- **Dual speakers:**

Audio volumes: 85 dBA @ 30 cm

Tone: Power, Radio and Auto mode: continuous tone (different pitch for each tone).
8 kHz and 33 kHz mode: pulsed tone (different pitch for each tone).
All five tones are different.

- **Pneumatic headphone sockets are integrated**

Internal battery

Type: 6 x LR6 (AA) alkaline
Typical operating time: 40 hrs intermittent use at 20°C / 68°F; in 8 kHz mode or 33 kHz mode

Instrument dimensions

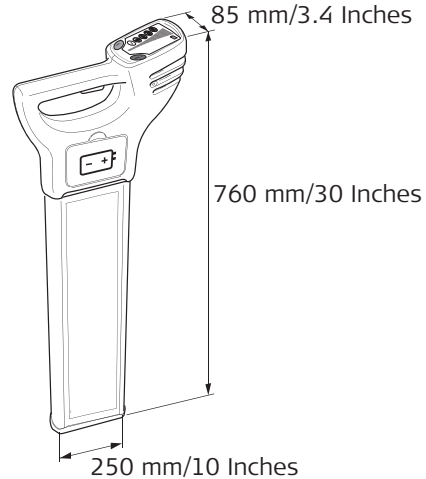

Weight

Instrument: 2.7 kg / 6 lbs
(including batteries)

Environmental specifications

Type		Description
Temperature	Operating	-20°C to +50°C -4°F to +122°F
	Storage	-40°C to +70°C -40°F to +158°F
Protection	against Water, Dust and Sand	IP54 (IEC 60529) Dust-protected
Humidity		95% RH non condensing The effects of condensation are to be effectively counteracted by periodically drying out the product.

Conformity to national regulations

- FCC Part 15 (applicable in US)
- Hereby, Cable Detection Ltd, declares that the EZiCAT i500/i550 is in compliance with the essential requirements and other relevant provisions of Directive 1999/5/EC. The declaration of conformity may be consulted at <http://www.cabledetection.co.uk/ce>.



Class 1 equipment according European Directive 1999/5/EC (R&TTE) can be placed on the market and be put into service without restrictions in any EEA member state.

- The conformity for countries with other national regulations not covered by the FCC part 15 or European directive 1999/5/EC has to be approved prior to use and operation.

Frequency band

50 Hz to 60 kHz

Output power

Receive only

10.2

Transmitter Technical Data

Typical detection range

Mode	Distance
Induction mode	150 m / 490 ft
Connection mode	250 m / 820 ft

Operating transmission frequencies

- 8.192 (8) kHz or
- 32.768 (33) kHz

Display panel

- 10 segment LED bar graph
- 4 LED mode indicators
- LED battery status indicator
- Led On/Off indicator
- LED signal output indicator

Keypad

4 membrane push buttons

Integral Speakers

Audio volumes: 51 dBA @ 30 cm
Tone:
8 kHz mode: Low pitched tone
33 kHz mode: Higher pitched tone
Induction mode: Continuous tone
Connection mode: Pulsed tone when poor or no current output, continuous tone when good connection

Internal battery

Type: 4 x LR14 (C) alkaline, supplied
Typical operating time: 40 hrs intermittent use at 20°C / 68°F; in Connection mode

Instrument dimensions

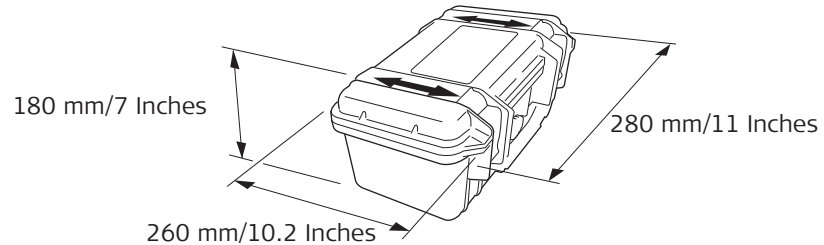

Weight

Instrument: 2.95 kg / 6.5 lbs
(including batteries)

Environmental specifications

Type		Description
Temperature	Operating	-20°C to +50°C -4°F to +122°F
	Storage	-40°C to +70°C -40°F to +158°F
Protection against Water, Dust and Sand	With cover open	IP54 (IEC 60529) Dust-protected
	With cover closed and secured	IP67 (IEC 60529) Dust tight Waterproof to 1 m temporary immersion
Humidity		95% RH non condensing The effects of condensation are to be effectively counteracted by periodically drying out the product.

Conformity to national regulations

- FCC Part 15 (applicable in US)
 - Hereby, Cable Detection Ltd, declares that the EZiTRACE is in compliance with the essential requirements and other relevant provisions of Directive 1999/5/EC. The declaration of conformity may be consulted at <http://www.cabledetection.co.uk/ce>.
-  Class 1 equipment according European Directive 1999/5/EC (R&TTE) can be placed on the market and be put into service without restrictions in any EEA member state.
- The conformity for countries with other national regulations not covered by the FCC part 15 or European directive 1999/5/EC has to be approved prior to use and operation.

Frequency band

8 kHz and 33 kHz

Output power

100 mW maximum, when directly connected to a buried service with a ground impedance of 100 Ohm or less.

10.3**Conductive Rod Technical Data**

Typical detection range Both modes, Line and Sonde: Typical 3.0 m / 10 ft

Tracing distance 30 m/99 ft; 50 m/165 ft; 80 m/263 ft (maximum).
Reel length dependant

Operating transmission frequencies

- 8.192 (8) kHz or
- 32.768 (33) kHz

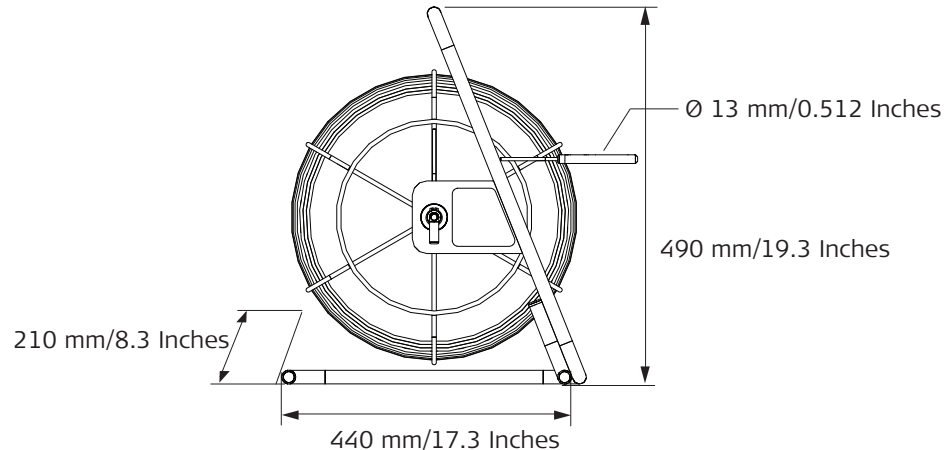
Instrument dimensions**Weight**

Instrument: 7.3 kg / 16.1 lbs

Environmental specifications

Type		Description
Temperature	Operating	-20°C to +50°C -4°F to +122°F
	Storage	-40°C to +70°C -40°F to +158°F
Protection against Water, Dust and Sand	Frame	IP54 (IEC 60529) Dust-protected
	Rod	Fully submersible
Humidity		95% RH non condensing The effects of condensation are to be effectively counteracted by periodically drying out the product.

Conformity to national regulations

- FCC Part 15 (applicable in US)
 - Hereby, Cable Detection Ltd, declares that the Conductive Rod is in compliance with the essential requirements and other relevant provisions of Directive 1999/5/EC. The declaration of conformity may be consulted at <http://www.cabledetection.co.uk/ce>.
-  Class 1 equipment according European Directive 1999/5/EC (R&TTE) can be placed on the market and be put into service without restrictions in any EEA member state.
- The conformity for countries with other national regulations not covered by the FCC part 15 or European directive 1999/5/EC has to be approved prior to use and operation.

10.4

Sonde Technical Data

Operating transmission frequencies

- 8.192 (8) kHz or
- 32.768 (33) kHz

Internal battery

Type: 1 x LR6 (AA) alkaline
Typical operating time: 40 hrs intermittent use at 20°C / 68°F; in 8 kHz mode or 33 kHz mode

Instrument dimensions

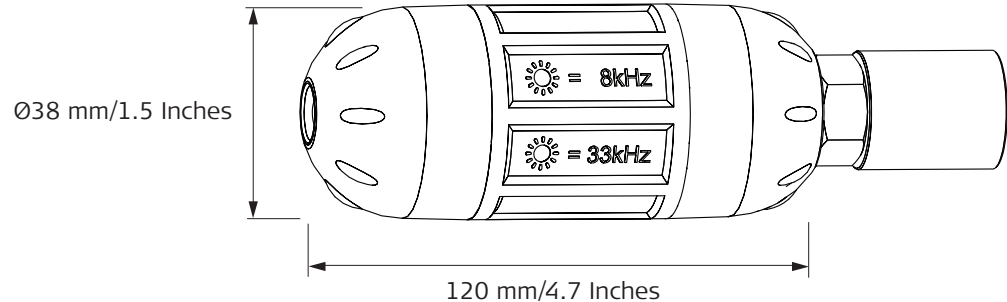

Weight

Instrument: 0.18 kg / 0.4 lbs
(including batteries)

Environmental specifications

Type		Description
Temperature	Operating	-20°C to +50°C -4°F to +122°F
	Storage	-40°C to +70°C -40°F to +158°F
Protection	against Water, Dust and Sand	Fully submersible
Humidity		95% RH non condensing The effects of condensation are to be effectively counteracted by periodically drying out the product.

Conformity to national regulations

- FCC Part 15 (applicable in US)
- Hereby, Cable Detection Ltd, declares that the Sonde is in compliance with the essential requirements and other relevant provisions of Directive 1999/5/EC. The declaration of conformity may be consulted at <http://www.cabledetection.co.uk/ce>.



Class 1 equipment according European Directive 1999/5/EC (R&TTE) can be placed on the market and be put into service without restrictions in any EEA member state.

- The conformity for countries with other national regulations not covered by the FCC part 15 or European directive 1999/5/EC has to be approved prior to use and operation.

10.5

Property Connection Set Technical Data

Operating transmission frequencies

- 8.192 (8) kHz or
- 32.768 (33) kHz

Instrument dimensions

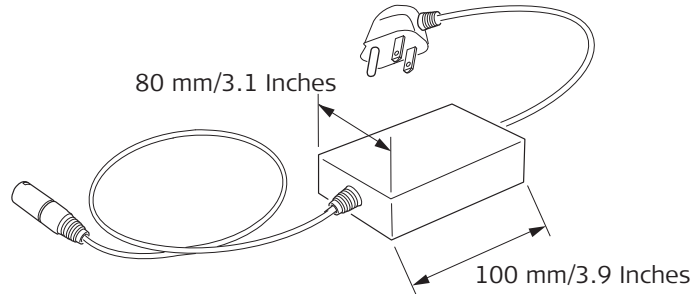

Weight

Instrument: 0.15 kg / 0.3 lbs

Environmental specifications

Type		Description
Temperature	Operating	-20°C to +50°C -4°F to +122°F
	Storage	-40°C to +70°C -40°F to +158°F
Protection	against Water, Dust and Sand	IP54 (IEC 60529) Dust-protected

Type	Description
Humidity	95% RH non condensing The effects of condensation are to be effectively counteracted by periodically drying out the product.

Conformity to national regulations

- FCC Part 15 (applicable in US)
- Hereby, Cable Detection Ltd, declares that the Property Connection Set is in compliance with the essential requirements and other relevant provisions of Directive 1999/5/EC. The declaration of conformity may be consulted at <http://www.cabledetection.co.uk/ce>.



- Class 1 equipment according European Directive 1999/5/EC (R&TTE) can be placed on the market and be put into service without restrictions in any EEA member state.
- The conformity for countries with other national regulations not covered by the FCC part 15 or European directive 1999/5/EC has to be approved prior to use and operation.

10.6

Signal Clamp Technical Data

Operating transmission frequencies

32.768 (33) kHz
when used with a signal transmitter set in 33 kHz mode.

Instrument dimensions

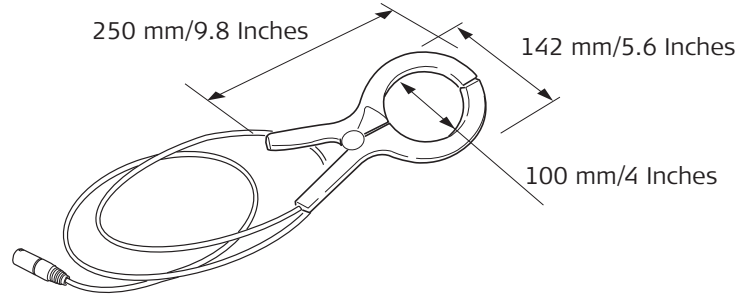

Weight

Instrument: 0.354 kg / 0.76 lbs

Environmental specifications

Type		Description
Temperature	Operating	-20°C to +50°C -4°F to +122°F
	Storage	-40°C to +70°C -40°F to +158°F
Protection	against Water, Dust and Sand	IP54 (IEC 60529) Dust-protected

Type	Description
Humidity	95% RH non condensing The effects of condensation are to be effectively counteracted by periodically drying out the product.

Conformity to national regulations

- FCC Part 15 (applicable in US)
 - Hereby, Cable Detection Ltd, declares that the Signal Clamp is in compliance with the essential requirements and other relevant provisions of Directive 1999/5/EC. The declaration of conformity may be consulted at <http://www.cabledetection.co.uk/ce>.
- 
- Class 1 equipment according European Directive 1999/5/EC (R&TTE) can be placed on the market and be put into service without restrictions in any EEA member state.
- The conformity for countries with other national regulations not covered by the FCC part 15 or European directive 1999/5/EC has to be approved prior to use and operation.

11**International Limited Warranty**

**International Limited
Warranty**

This product is subject to the terms and conditions set out in the International Limited Warranty which you can download from the Cable Detection home page at <http://www.cabledetection.co.uk/internationalwarranty> or collect from your Cable Detection distributor. The foregoing warranty is exclusive and is in lieu of all other warranties, terms or conditions, expressed or implied, either in fact or by operation of law, statutory or otherwise, including warranties, terms or conditions of merchantability, fitness for a particular purpose, satisfactory quality and noninfringement, all which are expressly disclaimed.

Appendix A

A.1

Functional Checks

Locator Functional Check

Checking the function

Before any tests can be carried out it is vital to check the status of the unit, its batteries and basic functionality.

The following list is used to achieve this.

1. Inspection

- **Casing** The casing should be free of significant damage.
- **Labels** Body labels must be legible and intact. Display label must be free of damage and tears.
- **Battery hatch** The hatch must lock into place.
- **Battery holder** All the battery contacts and springs on the holder must be free of corrosion and the holder in good condition.
- **Battery contacts** The battery contacts must be free of corrosion.

Once the general condition of the Locator is established the Audio Visual test can be performed.

2. Audio / Visual display test

Upon depressing the trigger the Locator should test the display and speakers by illuminating each segment in the bar display, the mode and function indicators and depth display, the battery indicator light will illuminate throughout the display test. All LCDs must be operative and an audible output must be heard.

3. Battery / Functional self check

If there is no response when the trigger is activated or the low battery illuminates (or flashes) after the Audio / Visual display test, the batteries will have to be replaced. Use alkaline batteries. Replace all of the batteries at the same time.

Checking the performance

The purpose of the following procedure is to verify the performance of the Locator. It is important that the test is conducted away from areas of electromagnetic interference or over buried services with a large signal radiating off them.

1. Switch the Locator on.
2. Whilst in Power mode hold down the **i** Button, until the settings are displayed.
3. Using the Function Button toggle through the settings until **EST** is displayed.
4. Press the **i** Button to activate the test.
5. Observe the displayed output:
 - PAS** means unit is within set tolerances.
 - ERR** means unit is outside set tolerances and may need servicing.



- Repeat the test in a different location if the units displays **ERR**.
- The Locator will automatically repeat the function test if it fails.
- Repeated failure will indicate a faulty unit, which must be returned for service.

Checking depth indication (i550 only)

This test can be carried out provided the depth of a service on the test area is known.

1. Switch the Locator on and ensure that it is in 33 kHz mode.
2. Position the Locator directly over and at right angle to the service.
3. Press and release the **i** Button to activate the depth measurement.
4. Record the depth.
5. If the depth reading deviates from the normal value or an error code is displayed, the Locator should be returned for service.



If any of these tests give no response or a significantly different response from normal, the Locator should be returned for service.

Functional test check list

Functional Test Check List					
Unit: Locator...	Serial Number:			Comments:	
Test	Operative			Fail analysis	Notes
	Yes	No	N/A		
1. Casing				Return for repair/ Replace	Casing should be free of damage.
2. Labels				Return for repair/ Replace	Body labels must be legible and intact. Display label must be free of damage and tears.
3. Battery hatch				Return for repair/ Replace	Hatches must be free of corrosion.
4. Battery holder				Replace	Holder must be free of corrosion.
5. Battery contacts				Return for repair	Contacts must be free of corrosion.
6. Audio / Visual display test				Return for repair	LCD is illuminated and an audible output must be heard.

Functional Test Check List					
7. Batteries				Replace	Replace alkaline batteries if pack is exhausted (no response) or if the battery indicator light is illuminated or flashing after display test. Replace all batteries !
8. Power mode				Return for repair	Response width and peak value similar to test unit.
9. Radio mode				Return for repair	Response width and peak value similar to test unit.
10. 8 kHz				Return for repair	Response width and peak value similar to test unit.
11. 33 kHz				Return for repair	Response width and peak value similar to test unit.
12. Depth Mode (i550 only) 8 kHz and 33 kHz				Return for repair	Gives same result as test unit (10% accuracy).
Tested by:					Date:

Checking the function

The purpose of the following procedure is to verify the performance of the signal Transmitter.

Before any tests can be carried out it is vital to check the status of the unit, its batteries and basic functionality.

To carry out this test the following are required:

- A Locator to detect the signals.
- A test area free of services as illustrated.

1. Inspection

- **Casing** The casing should be free of significant damage.
- **Labels** Body labels must be legible and intact. Display label must be free of damage and tears.
- **Battery hatch** The hatch must lock into place.
- **Battery holder** All the battery contacts and springs on the holder must be free of corrosion and the holder in good condition.
- **Battery contacts** The battery contacts must be free of corrosion.

Once the general condition of the Transmitter is established the Audio Visual test can be performed.

2. Audio / Visual display test

Turn on the Transmitter. The LED display will illuminate and the speakers will emit a tone, the battery/output level indicator will illuminate throughout the test. All LEDs must be operative and an audible output must be heard.

3. Battery check

Battery status is momentarily indicated after the Audio / Visual display test. The battery level indicator will indicate the condition of the battery. When the batteries need replacing the battery indicator will flash. Use alkaline batteries. Replace all of the batteries at the same time.

4. Inductive mode check

Turn on the Transmitter and Locator both set to 33 kHz mode. At a distance of 2 m/6.56 ft, the Locator should detect and indicate with both the audio and visual indicators. Change the Transmitter and Locator modes to 8 kHz and repeat. The speed of the audio pulsed output of both Transmitter and Locator should slow down.

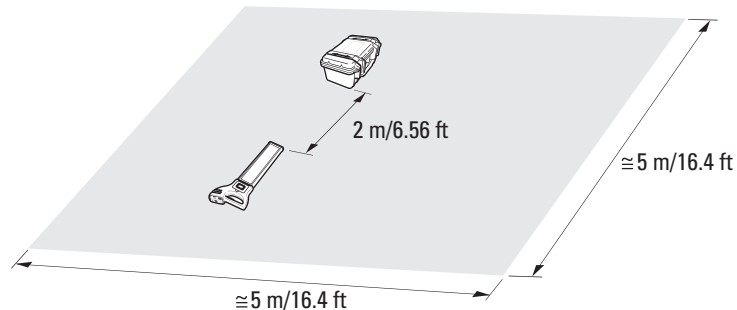

5. Output signal level check

Press the output level control button, the indicated power should reduce to minimum and then increase with repeated presses until the maximum level is again reached.

6. Connection mode check

With the Transmitter operating in the 33 kHz Induction mode, plug in the transmitter's cable set. The pulsing audio tone should change and the connection/induction LED change to indicate that the output has automatically changed over to the connection mode.

Connect the transmitter's cable set together, the output audio tone should change from pulsed to continuous and the Level meter display should read maximum.

Turn on the Locator set to 33 kHz mode and place it over one of the output connection cables.

The Locator should detect and indicate with both audio and visual indicators.

Change the Transmitter and Locator modes to 8 kHz and repeat. The speed of the audio pulsed output of the Transmitter should slow down.



If any of these tests give no response or a significantly different response from normal, the Transmitter should be returned for service.

Functional test check list

Functional Test Check List					
Unit: Transmitter...	Serial Number:			Comments:	
Test	Operative			Fail analysis	Notes
	Yes	No	N/A		
1. Casing				Return for repair/ Replace	Casing should be free of damage.
2. Labels				Return for repair/ Replace	Body labels must be legible and intact. Display label must be free of damage and tears.
3. Battery cover and accessory cover				Return for repair/ Replace	Hatches must lock into place.
4. Battery contacts				Return for repair	Contacts must be free of corrosion.
5. Audio / Visual display test				Return for repair	All LEDs must illuminate and an audible output must be heard.
6. Batteries				Replace	Replace alkaline batteries if exhausted (no response) or if the battery indicator light is illuminated or flashing after display test. Replace all batteries !

Functional Test Check List					
7. Induction mode				Return for repair/ Replace	Reduced or no output signal.
8. Connection mode; no change in audio indication				Return for repair/ Replace	Faulty cable.
9. Connection mode; no change in audio indication				Return for repair/ Replace	No output signal.
Tested by:					Date:

A.3**Conductive Rod Functional Check**

Checking the function

The purpose of the following procedure is to verify the performance of the Conductive Rod.

To carry out this test the following are required:

- A Transmitter for generating the signal in the Sonde and Line mode tests
- The cable set for the Conductive Rod.

Insert the Conductive Rod's cable set into the Transmitter and Conductive Rod. Ensure the black cable is connected. Switch the Transmitter on. The audible output from the Transmitter must be constant. Adjust the signal output on the Transmitter to minimum, the audible output must be constant. Part the black cable set in the middle, the audible output must be pulsed.



If any of these tests give no response or a significantly different response from normal, the Conductive Rod should be returned for service.

Functional test check list

Functional Test Check List					
Unit: Conductive Rod...		Serial Number:		Comments:	
Test	Operative			Fail analysis	Notes
	Yes	No	N/A		
1. Sonde mode: Transmitter audio output does not go continuous				Repair or replace cable set	Faulty cable.
2. Sonde mode: Locator does not detect signal				Return for repair/ Replace	One or both internal wires are open or short circuit.
3. Line mode: Locator does not detect signal				Return for repair/ Replace	One or both internal wires are open or short circuit.
Tested by:					Date:

A.4

Sonde Functional Check

Checking the function

The purpose of the following procedure is to enable a user to verify the performance of the Sonde.

To carry out this test the following are required:

- A Locator to detect the signal.
- A work area free of services as illustrated.

1. Inspection

- **Casing**

The casing should be free of significant damage, with the sealing ring and the screw thread intact

Once the general condition of the Sonde is established the self test can then be used to indicate the basic unit function and state of the batteries.

2. LED test

Turn on the sonde, the led display will illuminate.

3. Battery check

A dull LED, and lack of detection range will indicate poor battery condition. Use alkaline batteries.

1. Switch sonde on and activate 33kHz mode.
2. Set Locator to 33 kHz mode and aim at Sonde (see diagram).
3. At 2 m/6.56 ft the Locator must be at maximum.
4. Repeat this with Sonde and Locator in 8 kHz.

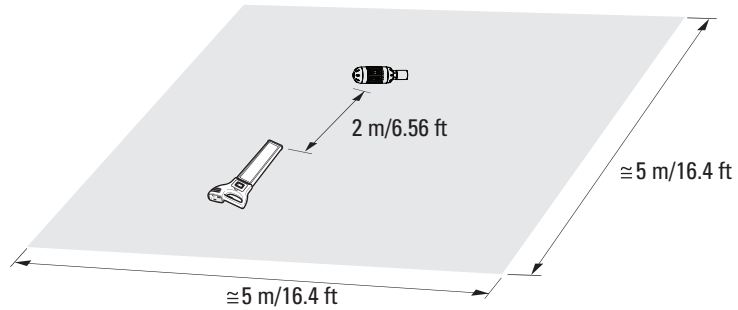

If any of these tests give no response or a significantly different response from normal, the Sonde should be returned for service.

Functional test check list

Functional Test Check List					
Unit: Sonde...	Serial Number:			Comments:	
Test	Operative			Fail analysis	Notes
	Yes	No	N/A		
1. Casing				Fail	Casing should be free of damage.
2. Screw thread and seal				Fail	Screw thread must be intact and seal in place.
3. Battery contacts				Fail	Contacts must be free of corrosion.
4. 33 kHz mode				Fail	LED must be illuminated brightly and pulse fast. Locator must provide maximum display at 2 metres.
5. 8 kHz mode				Fail	LED must be illuminated brightly and pulse slowly. Locator must provide maximum display at 2 metres.
Tested by:				Date:	

Appendix B

World Frequency Zones

North America

Canada	120 V / 60 Hz
United States	120 V / 60 Hz
Mexico	120 V / 50 Hz, 60 Hz

Central America

Bahamas	115 V / 60 Hz
Barbados	115 V / 50 Hz
Belize	110-220 V / 60 Hz
Bermuda	115 V / 60 Hz
Costa Rica	120 V / 60 Hz
Cuba	115-120 V / 60 Hz
Dominican Republic	110-220 V / 60 Hz
El Salvador	120-240 V / 60 Hz
Guatemala	115-230 V / 60 Hz
Haiti	110-220 V / 60 Hz
Honduras	110-220 V / 60 Hz
Jamaica	220 V / 50 Hz
Netherland Antilles	110-127 V / 50 Hz
Nicaragua	120 V / 60 Hz
Panama	120 V / 60 Hz
Puerto Rico	120 V / 60 Hz
Trinidad & Tobago	115-230 V / 60 Hz
Virgin Islands	120 V / 60 Hz

South America

Argentina	230 V / 50 Hz
Bolivia	110 V / 50 Hz
Brazil	110-127-220 V / 60 Hz
Chile	220 V / 50 Hz
Colombia	110-220 V / 60 Hz
Ecuador	110-220 V / 60 Hz
French Guiana	220 V / 50 Hz
Guyana	110-240 V / 60 Hz
Paraguay	220 V / 60 Hz
Peru	220 V / 60 Hz
Surinam	110-127 V / 60 Hz
Uruguay	220 V / 50 Hz
Venezuela	120-240 V / 60 Hz

Australia, Oceania

Australia	240 V / 50 Hz
Fiji Islands	240 V / 50 Hz
New Zealand	230 V / 50 Hz
Solomon Island	240 V / 50 Hz
Tonga	230 V / 50 Hz

Europe

Albania	230 V / 50 Hz	Slovenia	230 V / 50 Hz
Austria	230 V / 50 Hz	Spain	230 V / 50 Hz
Belgium	230 V / 50 Hz	Sweden	230 V / 50 Hz
Belarus	230 V / 50 Hz	Switzerland	230 V / 50 Hz
Bulgaria	230 V / 50 Hz	Ukraine	230 V / 50 Hz
Croatia	230 V / 50 Hz	United Kingdom	230 V / 50 Hz
Czech Republic	230 V / 50 Hz	Yugoslavia	230 V / 50 Hz
Denmark	230 V / 50 Hz		
Estonia	230 V / 50 Hz		
Finland	230 V / 50 Hz		
France	230 V / 50 Hz		
Germany	230 V / 50 Hz		
Greece	230 V / 50 Hz		
Hungary	230 V / 50 Hz		
Iceland	230 V / 50 Hz		
Ireland	230 V / 50 Hz		
Italy	230 V / 50 Hz		
Latvia	230 V / 50 Hz		
Lithuania	230 V / 50 Hz		
Luxemburg	230 V / 50 Hz		
Moldavia	230 V / 50 Hz		
Netherlands	230 V / 50 Hz		
Norway	230 V / 50 Hz		
Poland	230 V / 50 Hz		
Portugal	230 V / 50 Hz		
Romania	230 V / 50 Hz		
Russia	230 V / 50 Hz		
Slovakia	230 V / 50 Hz		

Africa

Algeria	127-220 V / 50 Hz	Niger	220 V / 50 Hz
Angola	220 V / 50 Hz	Nigeria	230 V / 50 Hz
Benin	220 V / 50 Hz	Rwanda	220 V / 50 Hz
Botswana	220 V / 50 Hz	Senegal	110 V / 50 Hz
Burkina Faso	220 V / 50 Hz	Sierra Leone	230 V / 50 Hz
Burundi	220 V / 50 Hz	Somalia	220 V / 50 Hz
Cameroon	127-220 V / 50 Hz	South Africa	220-240 V / 50 Hz
Central Africa Rep.	220 V / 50 Hz	Sudan	240 V / 50 Hz
Chad	220 V / 50 Hz	Swaziland	220 V / 50 Hz
Congo	220 V / 50 Hz	Tanzania	230 V / 50 Hz
Dahomey	220 V / 50 Hz	Togo	127-220 V / 50 Hz
Egypt	220 V / 50 Hz	Tunisia	127-220 V / 50 Hz
Ethiopia	220 V / 50 Hz	Uganda	240 V / 50 Hz
Gabon	220 V / 50 Hz	Zaire	220 V / 50 Hz
Gambia	230 V / 50 Hz	Zambia	220 V / 50 Hz
Ghana	240 V / 50 Hz	Zimbabwe	220 V / 50 Hz
Ivory Coast	220 V / 50 Hz		
Kenya	240 V / 50 Hz		
Lesotho	220-240 V / 50 Hz		
Liberia	120 V / 60 Hz		
Libya	115-220 V / 50 Hz		
Malawi	230 V / 50 Hz		
Mali	220 V / 50 Hz		
Mauritania	220 V / 50 Hz		
Mauritius	230 V / 50 Hz		
Morocco	127-220 V / 50 Hz		
Mozambique	220 V / 50 Hz		
Namibia	220 V / 50 Hz		

Asia			
Abu Dhabi	230 V / 50 Hz	Oman	240 V / 50 Hz
Afghanistan	220 V / 50 Hz	Pakistan	230 V / 50 Hz
Armenia	220 V / 50 Hz	Philippines	110-220 V / 60 Hz
Azerbaijan	220 V / 50 Hz	Qatar	240 V / 50 Hz
Bahrain	110-230 V / 50 Hz, 60 Hz	Saudi Arabia	127-220 V / 50 Hz
Bangladesh	230 V / 50 Hz	Singapore	230 V / 50 Hz
Brunei	240 V / 50 Hz	Sri Lanka	230 V / 50 Hz
Cambodia	220 V / 50 Hz	Syria	220 V / 50 Hz
China	220 V / 50 Hz	Taiwan	110-220 V / 60 Hz
Cyprus	240 V / 50 Hz	Tajikistan	220 V / 50 Hz
Georgia	220 V / 50 Hz	Thailand	220 V / 50 Hz
Hong Kong	220 V / 50 Hz	Turkey	220 V / 50 Hz
India	230-250 V / 50 Hz, 60 Hz	Turkmenistan	220 V / 50 Hz
Indonesia	127-220 V / 50 Hz	United Arab Emirates	220 V / 50 Hz
Iran	220 V / 50 Hz	Uzbekistan	220 V / 50 Hz
Iraq	220 V / 50 Hz	Vietnam	120-220 V / 50 Hz
Israel	230 V / 50 Hz	Yemen	220 V / 50 Hz
Japan	100-220 V / 50 Hz, 60 Hz		
Jordan	220 V / 50 Hz		
Kazakhstan	220 V / 50 Hz		
Kirgizstan	220 V / 50 Hz		
Korea (North)	220 V / 50 Hz		
Korea (South)	110-220 V / 60 Hz		
Kuwait	240 V / 50 Hz		
Laos	220 V / 50 Hz		
Lebanon	110-220 V / 50 Hz		
Malaysia	240 V / 50 Hz		
Myanmar	240 V / 50 Hz		

Index

C	
Conductive Rod	
Functional Check	90
L	
Locator	
Functional Check	81
O	
Operating depth range	65
S	
Sonde	
Functional Check	92
T	
Technical Data	65
Temperature	
Conductive Rod	
Operating	73
Storage	73
Locator	
Operating	68
Storage	68
Property Connection Set	
Operating	76
Storage	76
Signal Clamp	
Operating	78
Storage	78
Sonde	
Operating	75
Storage	75
Transmitter	
Operating	70
Storage	70
Transmitter	
Functional Check	85
Typical depth accuracy	65
Typical detection range	
Distance	69
Distance along conductor	65

Cable Detection Ltd
Staffordshire, UK

www.cabledetection.co.uk

Total Quality Management: Our commitment to total customer satisfaction.



Cable Detection Ltd, Staffordshire, UK, has been certified as being equipped with a quality system which meets the International Standards of Quality Management and Quality Systems (ISO standard 9001).

Ask your local Cable Detection dealer for more information about our TQM program.

124006/1.0.0en

Original text

© 2010 Cable Detection Ltd,
Staffordshire, UK

