

RT-30EX - HAZARDOUS AREA RATED FLOW TRANSMITTER

Ideal for any industry or flow measurement application where an explosion-proof local rate & total display is required, such as in offshore chemical injection, hydraulic fracturing, or industrial paint spray booths.



BENEFITS

Easy Field Programming

Flow rate or total can be easily programmed to display in choice of engineering units. To program the unit simply use the magnet that is attached. No opening of the enclosure is required.

Options for Remote Indication

The RT-30EX has options for remote flow monitoring:

- Frequency pulse output (standard)
- 4-20mA, user scalable (standard)
- HART communication protocol (optional)

Remote Mounting Available

The RT-30EX can be mounted remotely when used with the HUB-40EX sensor or HUB-41EX.

Up and Running in Minutes

Easy thread-in installation. A quick setup procedure allows you to have the flow monitor working with just a few simple programming steps.

Flexible Mounting

Because of the integral swivel union, the RT-30EX unit can be rotated 360° for optimal viewing from any angle. Options available to fit any AW Gear Meter or Turbine Meter. Spring loaded sensor eliminates damage of mechanical design.

Weather-Proof Enclosure

NEMA 4X/IP-66 certified enclosure provides environmental protection from moisture and debris.

FEATURES

- Choose from Hazardous area certification options including: cCSAus, IECEx or ATEX
- HART® communication protocol option for remote monitoring and programming.
- For use with all AW-Lake EX flow meters.



TECHNICAL SPECIFICATIONS

Power Requirement

9-24 VDC / 200mA (customer supplied) Class 2

Digital Display

Graphic backlit LCD display offers a variety of screens:

- Rate*
- Total*
- Rate & Total*
- Grand Total*
- Status
- Analog Out
- Limit

Analog Output 4-20mA

3- or 2-wire plus separate supply
Max load impedance 500 ohm

Frequency Output

Three Opto-Isolated Open-Collector Outputs

- Frequency or limit outputs
- 5-30 VDC rating
- 40 mA max (min. load impedance required 600 Ohm @ 30 VDC)

Temperature Rating

-20 to 60°C (-4 to 140°F)

Built in 30 point Linearizer

Frequency Range

0-4,500 Hz

Connection

3/4" female NPT conduit provisions

One Opto-Isolated Input

9-24 VDC remote reset

cCSAus Certification

- Class I, Div. I, Groups C, D
- Class II, Div. I, Groups E, F, G
- Class III

ATEX Certification

II 2 G, Ex d IIB+H₂ T5 Gb,
Ta = -40°C to +60°C

IECEx Certification

Ex d IIB+H₂ T5 Gb
Ta = -40°C to +60°C

* Data displayed in up to 10 characters

PART NUMBER GUIDE

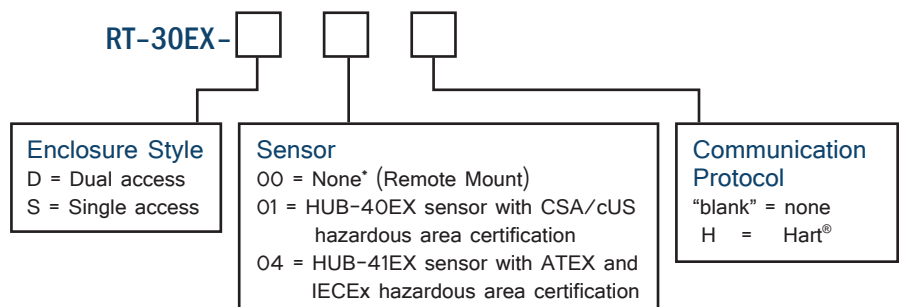

*Requires approved remote mount sensor from AW-Lake



2440 W. Corporate Preserve Dr. #600, Oak Creek, WI 53154 | www.aw-lake.com

RT-30EX - FLOW TRANSMITTER WITH LOCAL DISPLAY

Ideal for any industry or flow measurement application where a local rate and total display is required and in locations where equipment is exposed to the elements.

SINGLE ACCESS ENCLOSURE (SHOWN HERE WITH HUB-40 SENSOR)

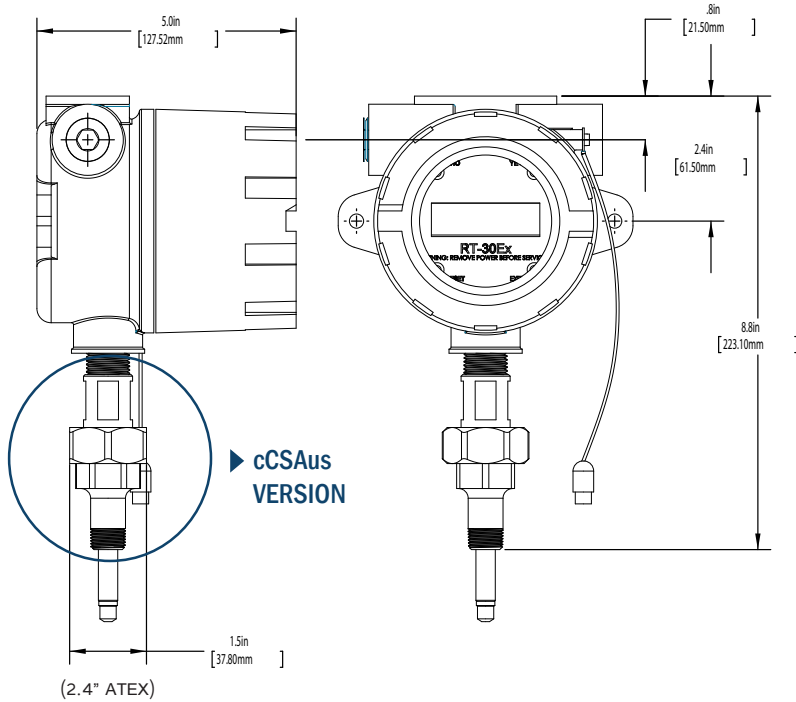

DUAL ACCESS ENCLOSURE (SHOWN HERE WITH HUB-41 SENSOR)

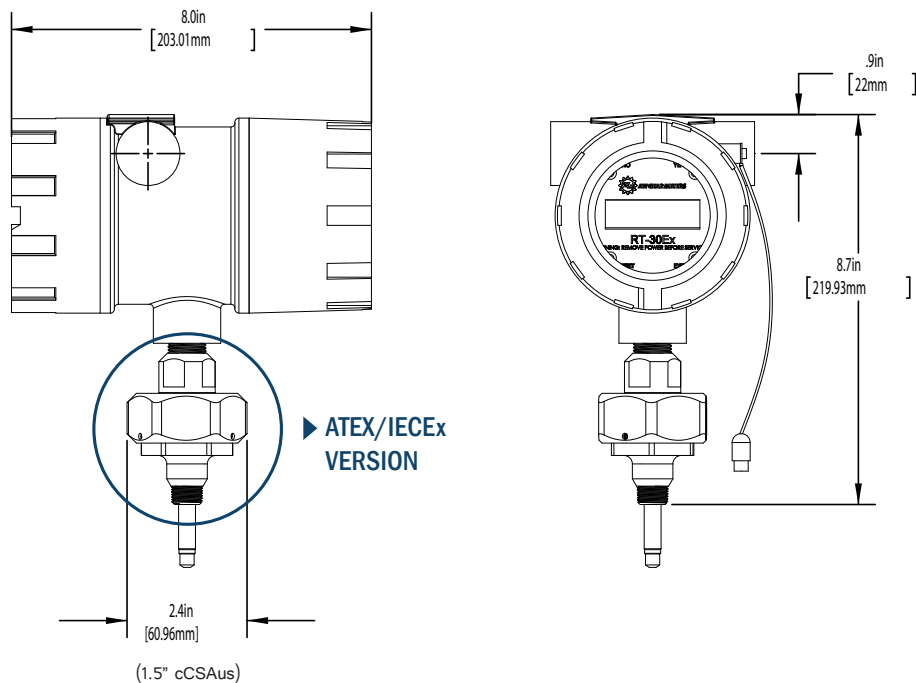

Products may be subject to change without notice - Contact factory for the most up-to-date product information.

